

COURSE UNIT 2



Construction Functions

Table of Contents

Introduction.....	2
Open project.....	3
Slab	4
External walls	6
Help lines	7
Inner walls	10
Doors	12
Edit / move AR-Object	15
Wall openings.....	17
Windows	18
Modify window division.....	20
Modify window parameters	22
Stairs	25
Stretch	30
Staircase opening in ground floor slab	31
Top floor slab	33
Walls / Doors top floor.....	35
Copy into active storey	37
Edit / delete AR object	38
Foundation slab with projection.....	41
Roof.....	44
Work plane on surface	47
Set window in view	49
Windows in top floor	51
Copy/mirror windows	53
Room label.....	54
Save	59

INTRODUCTION

How to use this course unit

This course unit is not a manual but a combination of theory and workshops with which to learn the programme on a 1-to-1 basis. Every mouse-click and every entry is described in detail, providing you with a teaching resource that lets you learn the basics of the programme by yourself. Each chapter provides explanations, information, and a workshop to practise the functions. To enable the workshops to be completed smoothly, the explanations should be read through very carefully. The order of chapters should not be changed because each workshop builds on the previous one. The installation of ELITECAD contains examples stored as an ELITECAD file, enabling problematic places to be reviewed.

Conventions used in this course unit

The start and end of a workshop are marked as follows:

▼ ▼ ▼ ▼ **WORKSHOP**

WORKSHOP END

Functions are written in block capitals. The corresponding icon also appears for new functions.

FUNCTIONS (BLOCK CAPITALS)



Functions can be accessed directly using icons (buttons). The functions are grouped together in tool bars or under tool management.

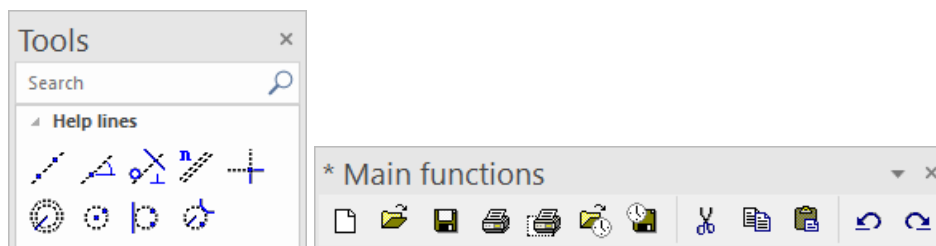

[Enter]

Function keys on the keyboard appear within square brackets.

Input values (bold)

Input values must be entered using the keyboard. When the text is entered in the input line, it must be confirmed with the [Enter] key.

OPEN PROJECT

The following exercise concerns a one-family home consisting of the three storeys Ground Floor (GF), Top Floor (TF) and Basement (BA). Create a project in accordance with course unit 1/Beginners.

▼ ▼ ▼ ▼ WORKSHOP

1. Open new project. If Storeys Manager is not visible on screen, it can be displayed with the key combination [Ctrl]+[2].

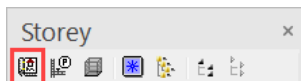

Specify the project name **Test_course** and confirm with OK. The mask "Structure - Settings" opens automatically.

2. Height marking on project null: **400** m.a.s.



3. Click NEW to create a structure.

Name: **House**, height situation: **400** m.a.s. Confirm entries with APPLY.

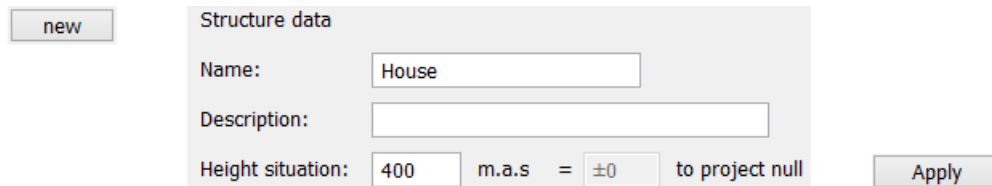

4. On the "height section" tab specify the room clearance and the number of storeys.

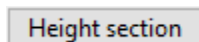

BA 2.35 m, GF 2.40 m and TF 2.70 m
Confirm entries with APPLY.

5. On the "Storeys" tab specify the floor gauge and ceiling gauge of all storeys.

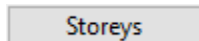

Floor gauge:
GF, TF 10 cm; BA 5 cm

raw slab gauge:
All storeys 20 cm

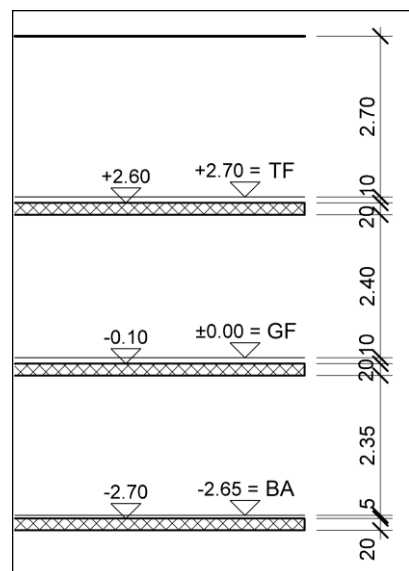

Per storey, confirm with APPLY.
Check heights, then click OK to close storey mask.

WORKSHOP END

SLAB

The basic shape of the building is rectangular. It does not matter whether the outer wall or the floor (slab) need to be drawn first.

You draw the structure to a scale of 1:100 and with representation mode "construction project".

▼ ▼ ▼ ▼ WORKSHOP

1. Set plan format, scale and unit > **A3, 1:100, cm.**
2. Set the representation mode to construction project.

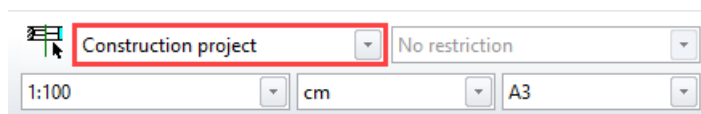

3. In Storeys Manager, select the ground floor as active storey.

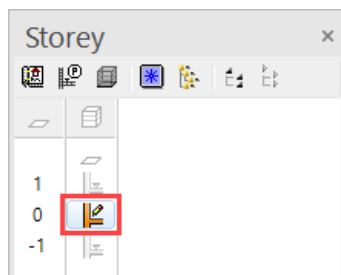

4. Select the function CREATE SLAB.



5. Switch to the parameter type *Standard* and, if necessary, to the entry mode *Draw contour manually*.

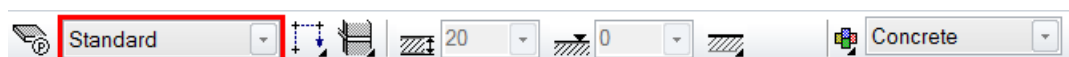

6. The drawing functions appear in the Input Assistant. Switch to the drawing function RECTANGLE.



7. Draw the rectangle.

Place point **P1** to the bottom left, then point **P2** using coordinates X value **1050**, Y value **900**.

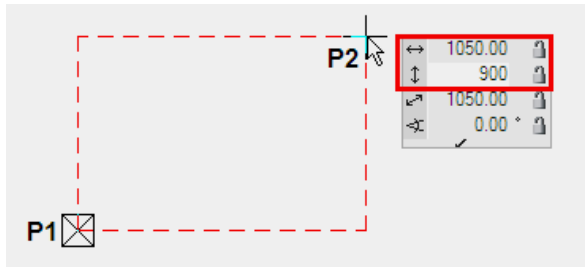

8. A slab has now been created from the polygon with the corresponding floor thickness of the ground floor. Cancel the function.

[Esc]

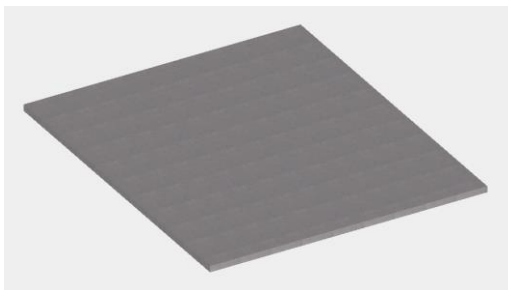

WORKSHOP END

EXPLANATION

Height reference for slab



Free slab

The thickness and upper edge of the slab can be freely defined. The walls have **no** reference to this slab.



Storey

The gauge and upper edge of the slab is predefined according to the height section.



Level

The thickness and upper edge of the slab can be freely defined. The walls refer to this slab.

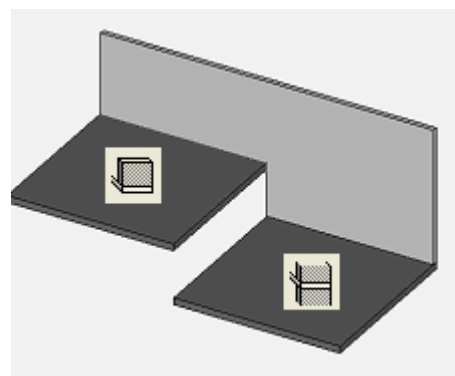

EXTERNAL WALLS

For the building permit, a single layered outer wall with a gauge of 30 cm is sufficient. The wall can be changed to multi-layered at any time.

WORKSHOP

1. Select the CREATE WALL function.



2. Adapt the settings marked in the properties bar.



3. From the input assistant select the drawing function RECTANGLE and create the rectangle over the two points **P1** and **P2**.

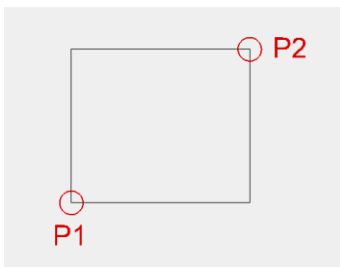

4. When the prompt *Which direction?* appears, move the cursor inside the structure and confirm with a left-click.

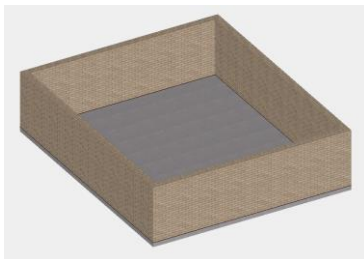

5. Cancel the function by pressing [Esc] and save a work copy [Ctrl]+[W].

WORKSHOP END

HELP LINES

You will now draw the help lines to define the most important help lines of the inner walls. Some help lines pass through the middle points of the edge or are located in the centre between two points. Thanks to the snap functions, a skilled drawer can save themselves some tedious calculations.

Entry mode

In the properties bar a distinction is made between two entry types that however only apply if there are multiple values. The individual values must be separated by a comma.

Relative parallel distances

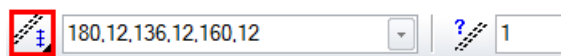

The distances are reapplied from every help line.

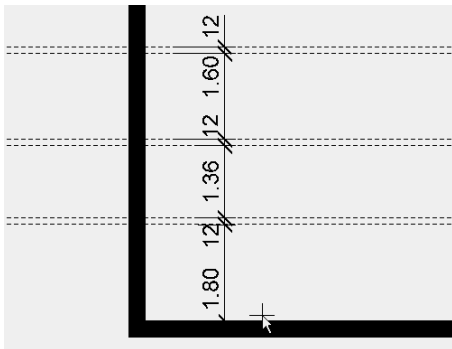

Absolute parallel distances

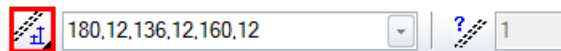

The distances are always transferred from the element that was originally clicked on.

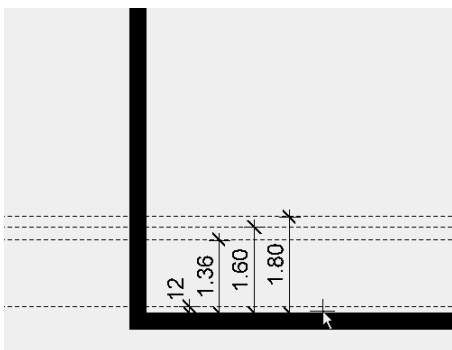

▼ ▼ ▼ ▼ WORKSHOP

1. First, draw a vertical help line in the axle of the structure.



As soon as the snap symbol *Middle of element* appears, you can set the help line.

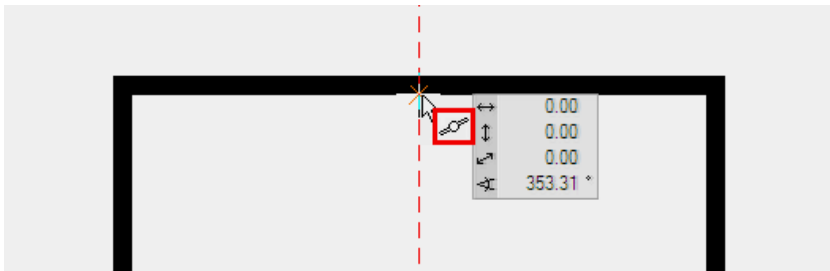

2. Now transfer other help lines with a parallel gap to the first line. The help lines are transferred to the side that you click on with your cursor.

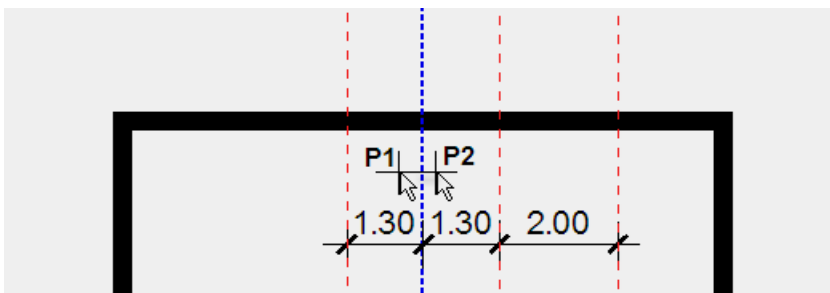
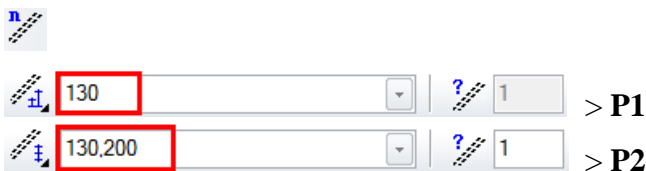

3. Supplement the horizontal help lines in the same way.

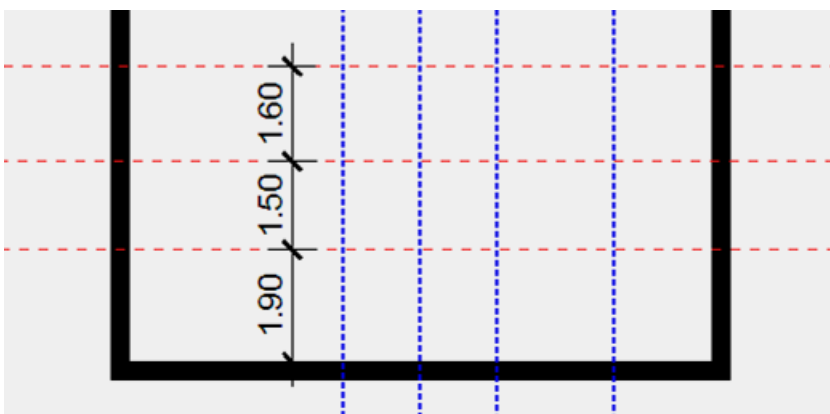

4. Use the CIRCLE BY RADIUS function to create a circle option. Enter the radius in the properties bar > 80. In addition, the circle is tangential to the two help lines. When

you select the help lines, the snap symbol *To element* must appear and **the cursor must be on the side of the help line that is shown.**

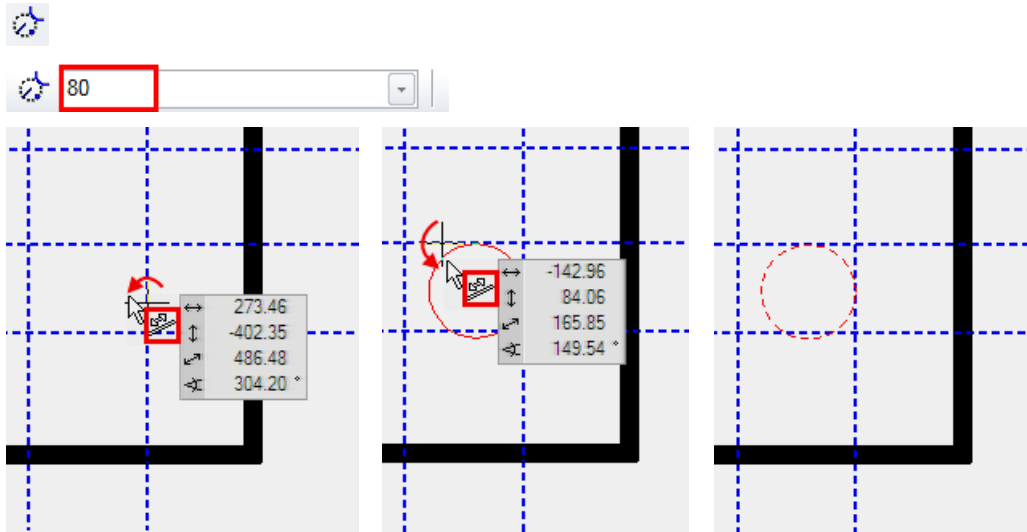

WORKSHOP END

INNER WALLS

The walls are defined by an axis. If changes are made to the gauge of a wall, the change will be re-transferred from the axis. For outer walls the axis must be located outside; for inner walls it is less important on which side the axle is located. As a rule, e.g. in staircases or corridors, the axis can always be created on the inside.

▼ ▼ ▼ ▼ WORKSHOP

Create the walls on the ground floor.

1. Select the CREATE WALL function and make the selected settings.

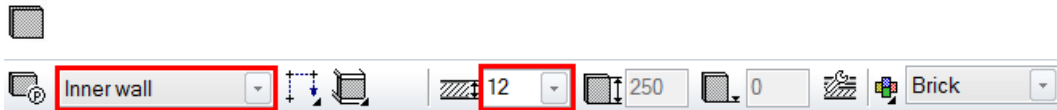

2. In the Input Assistant, the drawing function *Polygon* is selected as standard.



Create the inner walls. To finish a wall, click again on the end point.
Start point > **P1**; End point > **P2 double-click**; Direction: > **P3**

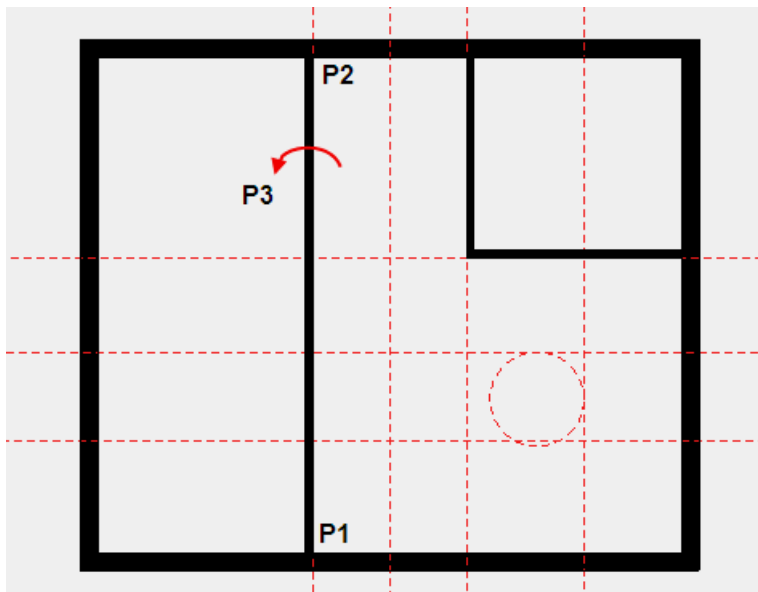

3. For the inner wall with the round corner, to draw the curve you must select the circle function *Curve over 3 points*.

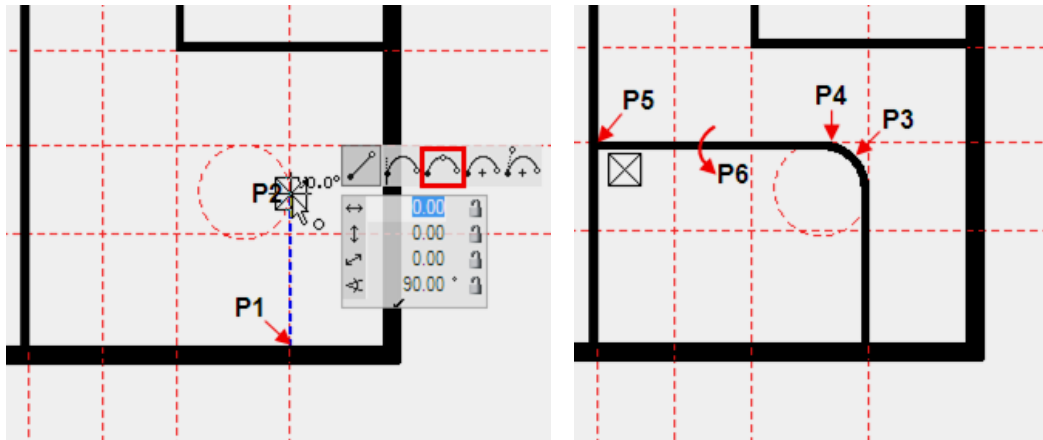

4. Create the rest of the inner walls.

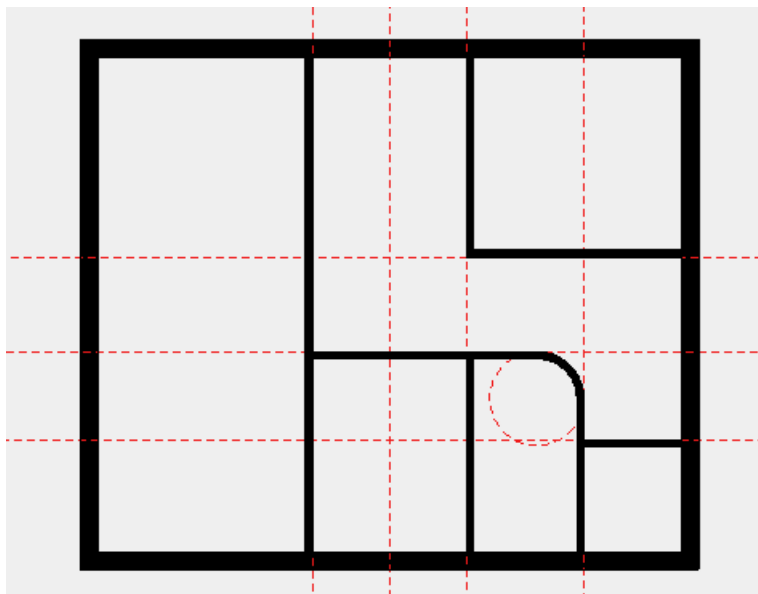

5. Delete help lines.



WORKSHOP END

EXPLANATION

Delete help lines

The function DELETE ALL HELP GEOMETRY deletes all of the help lines.



DOORS

The level of detail of the doors depends on the selected representation mode. The door main dimension such as width, height and threshold can be modified directly in the properties bar. In the door mask you define whether the values are transferred as raw or finished.

Finished clearance

Gross clearance

- 1) as of finished floor
- 2) as of slab

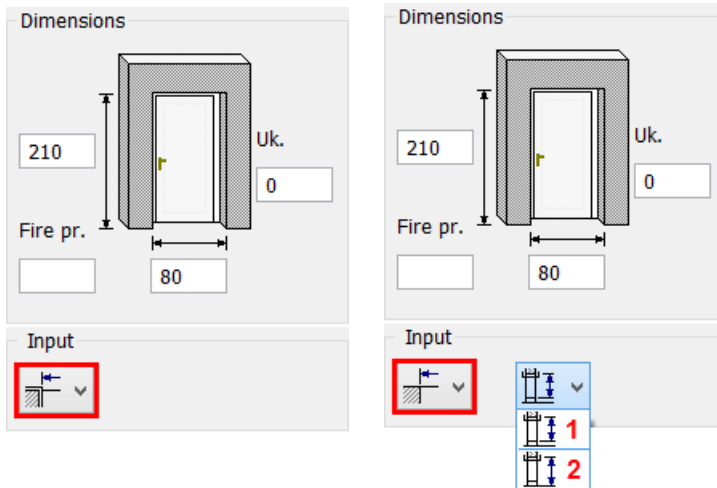

▼ ▼ ▼ ▼ WORKSHOP

Create the doors with the type "Standard".

1. Select the CREATE DOOR function and check the settings.



- Apply a temporary reference point **RP**, move the cursor to the wall and enter the distance of **70** cm.
 You can now define the placement with the mouse pointer. The door moves either to the left, to the right or to the centre of the positioning point **PP**.
 Left-click to place the door at the selected position.

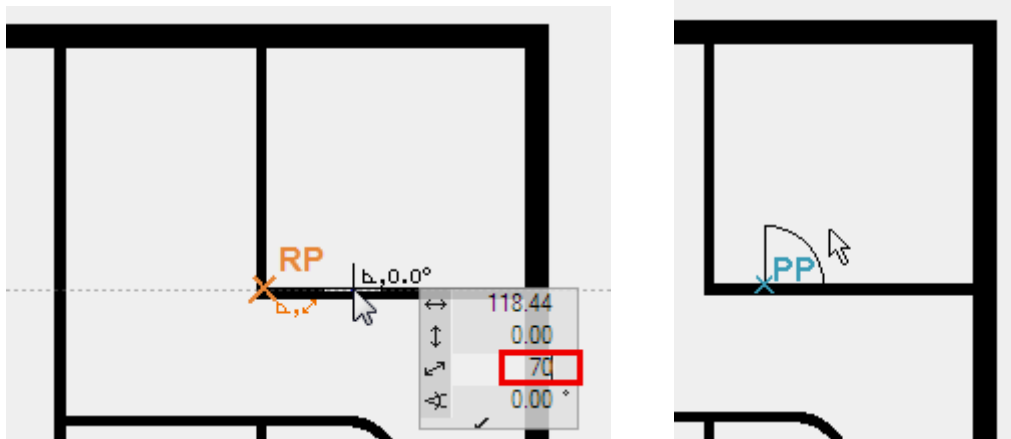

- Now add the remaining doors. The outer door is located in the centre of the wall and is 90 cm wide.

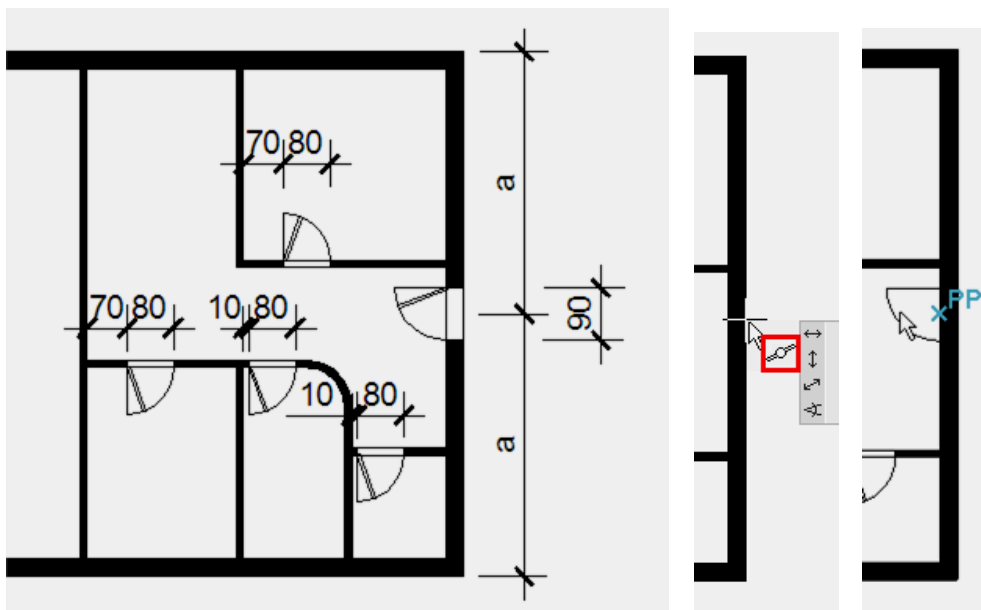

4. Sliding doors

Select the type "Sliding doors" and make the settings.



Place the sliding doors at a distance of 20 cm to the corner and locate the sliding doors in accordance with the template.

Model display Plan view

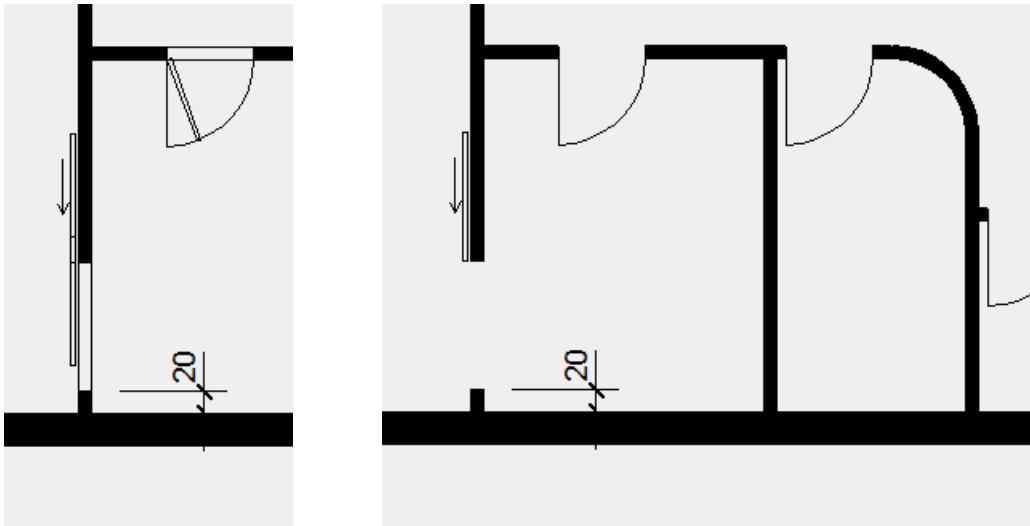

5. Cancel the function with [Esc].

WORKSHOP END

EDIT / MOVE AR-OBJECT

An incorrectly placed AR-Object can be very easily modified later on, or repositioned.

▼ ▼ ▼ ▼ WORKSHOP

The opening direction of a door is to be changed and the door must be moved in the wall.

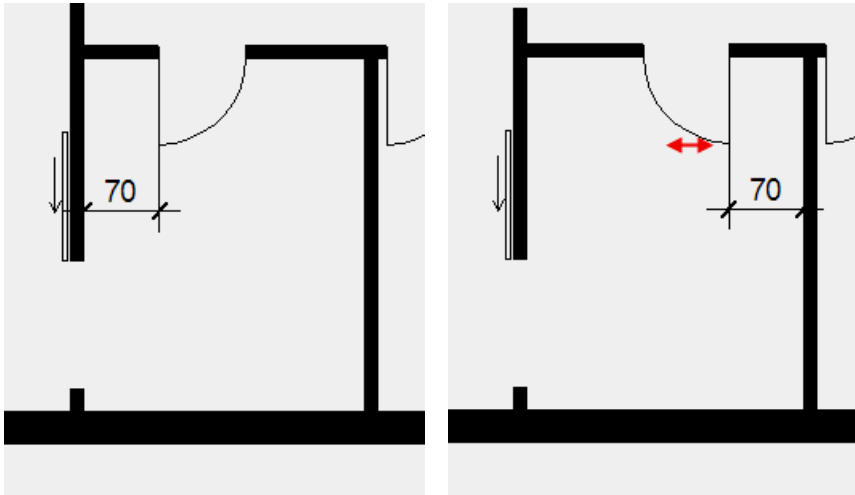

1. Change the door opening type.

The easiest way to select the door is to click on the curve > **P1**. Handles are assigned to the door and the properties bar is displayed with the settings for this door. In addition to the dimensions, change functions are also contained in the bar.

Select the function **MODIFY DOOR STOP**.

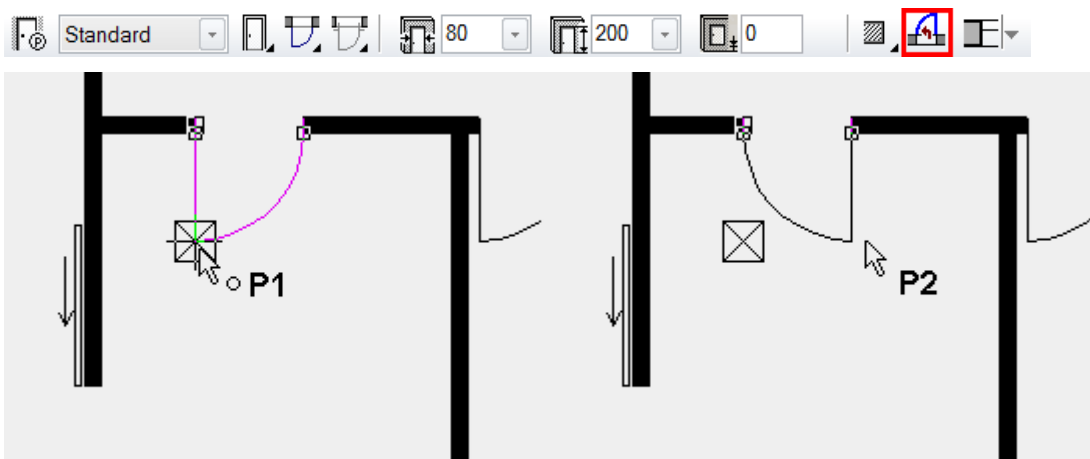

As soon as you select the function the door is ready for the change. Redefine the placement with the mouse pointer > **P2**.

2. The door is still active (magenta, properties bar and handles). It can now be moved directly.

Move the cursor on the door handle until the display symbol on the cursor changes to a double arrow. Select the handle > **P1**.

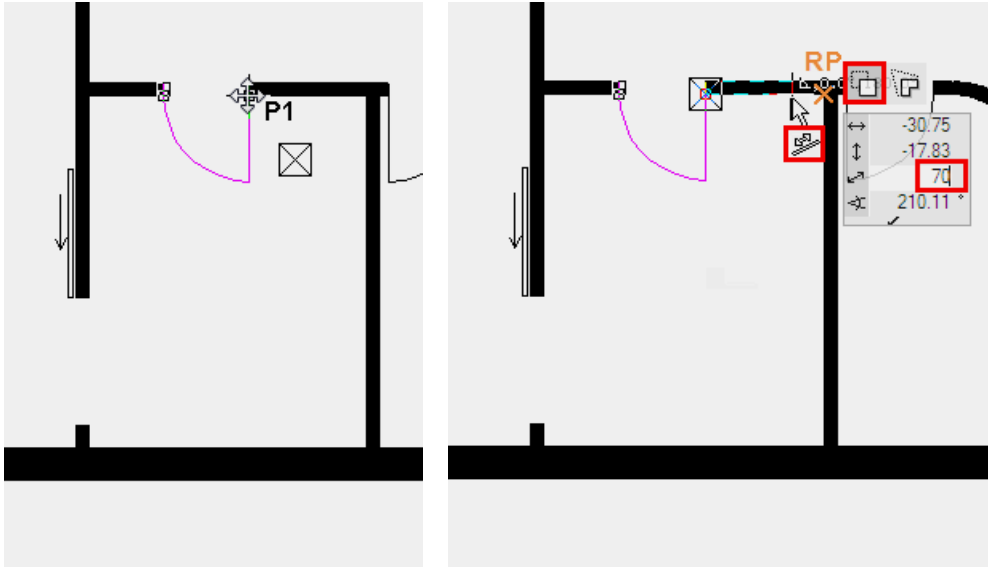

Select the move option (predefined as standard) and, using a temporary reference point, reposition the door with **70** cm to the room corner.

3. Cancel the function with [**Esc**].

4. Edit the outside door.

Select the outside door with a click and change the threshold height to 13 cm.



WORKSHOP END

WALL OPENINGS

A wall opening is a wall cutout without stop parameter. Later on, the wall opening can be reselected or edited on a diagonal blue line in the floor plan.

WORKSHOP

Set a wall opening in the middle of the corridor. This will teach you how to use the capture mode in the ideal way.

1. Select the CREATE WALL OPENING function and check the settings.



2. The wall opening is to be aligned towards the centre of the corridor. First set the temporary reference point **BP1** with the help of which you can set the reference point **BP2**. You can reach the middle point by setting the reference point **BP3**. Set the opening into the wall.

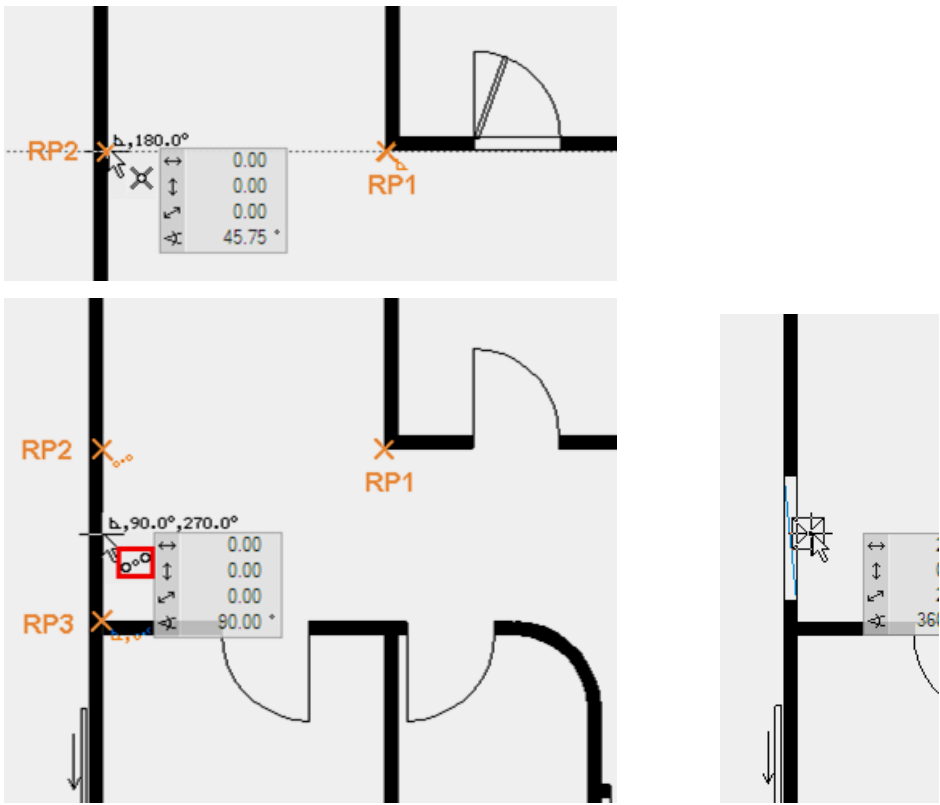

WORKSHOP END

WINDOWS

▼ ▼ ▼ ▼ WORKSHOP

In the floor plan, you will now draw windows of different sizes.

1. Select the function CREATE WINDOW. Select the type "Standard casement" and check the settings.

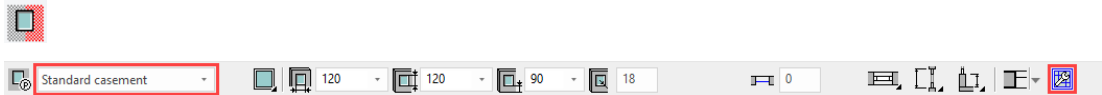

2. Select the function TOOL FOR WINDOW DIVISION / MUNTINS at the end of the properties bar.
3. Select the function SYMMETRIC CASEMENTS, check the settings and confirm your entries with APPLY.

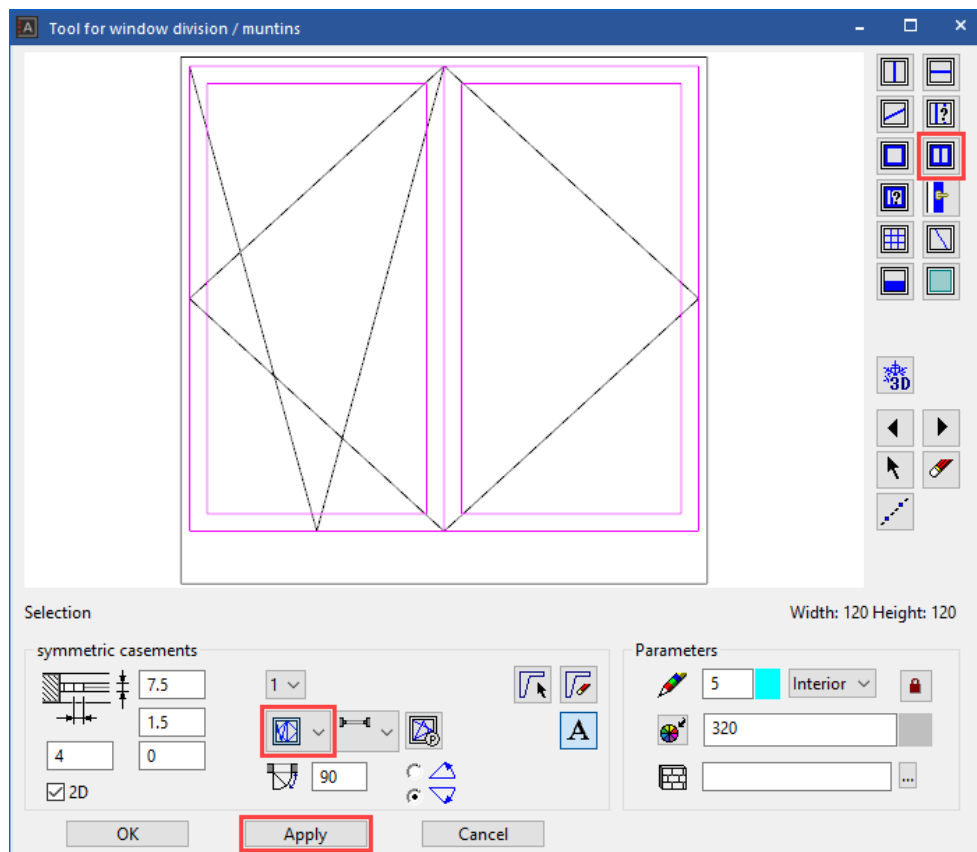

Click OK to close the screen.

4. Set the windows into the floor plan. When the window is finally set, the outside of the window is displayed with a line.

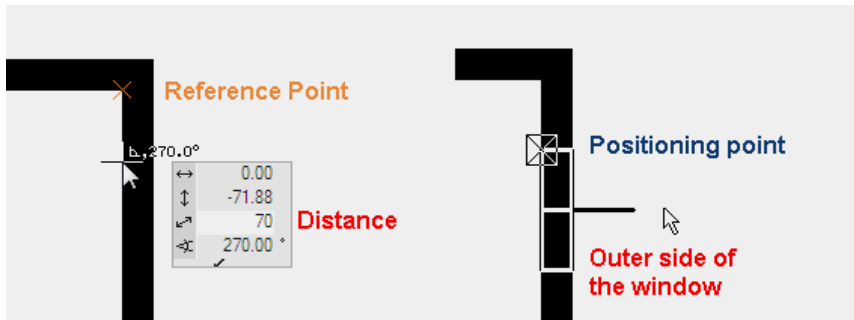

Take care to observe the different widths and heights.

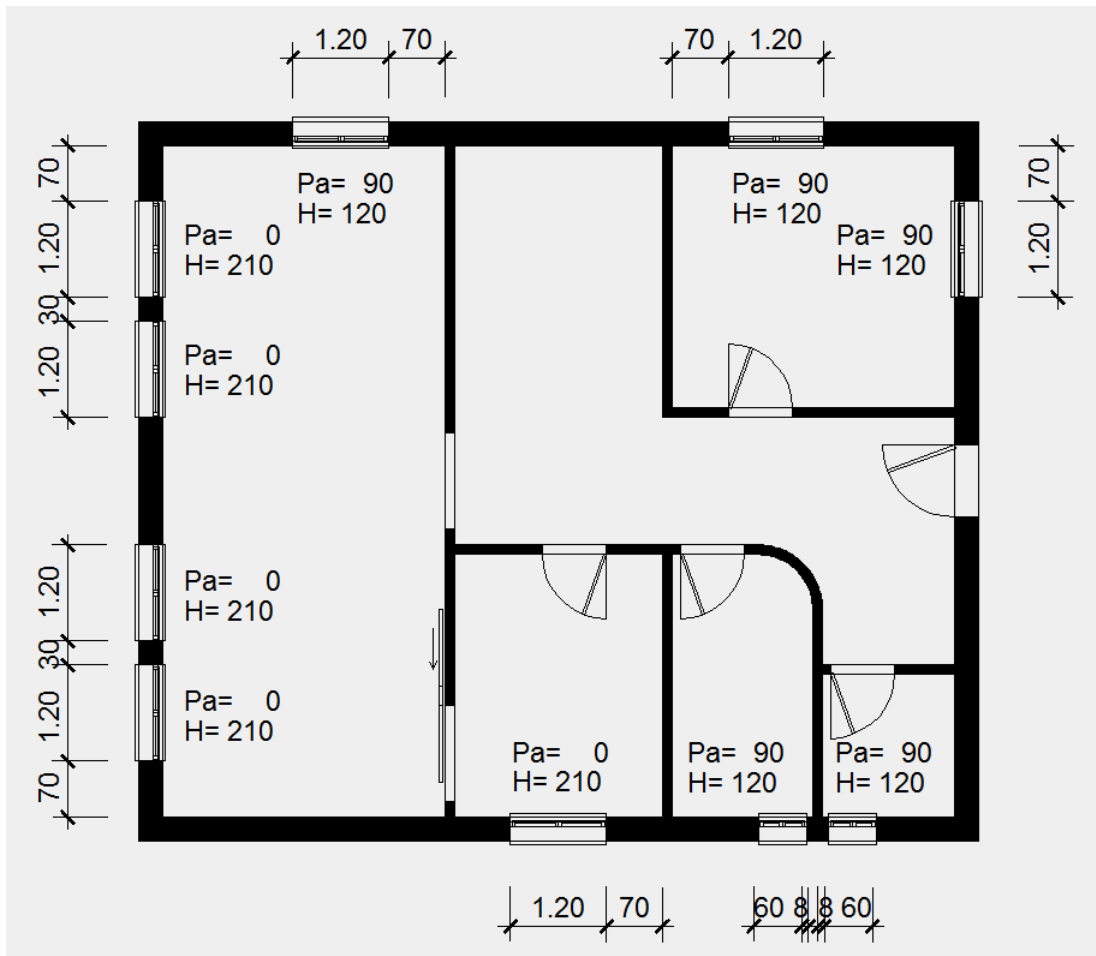

TIP

In the properties bar the dimensions can be easily entered and other windows set. The function is a *constraint*, until it is cancelled.

5. Save a work copy [Ctrl]+[W].

WORKSHOP END

MODIFY WINDOW DIVISION

▼ ▼ ▼ ▼ WORKSHOP

All of the windows you just created are double-casement windows. The small windows 60/120 must now be changed to single-casement.

1. Rotate the model lightly into 3D.

Rotate: Press and hold the centre mouse button (or wheel) and move the mouse.

Solid: **[Ctrl]+[D]** or 

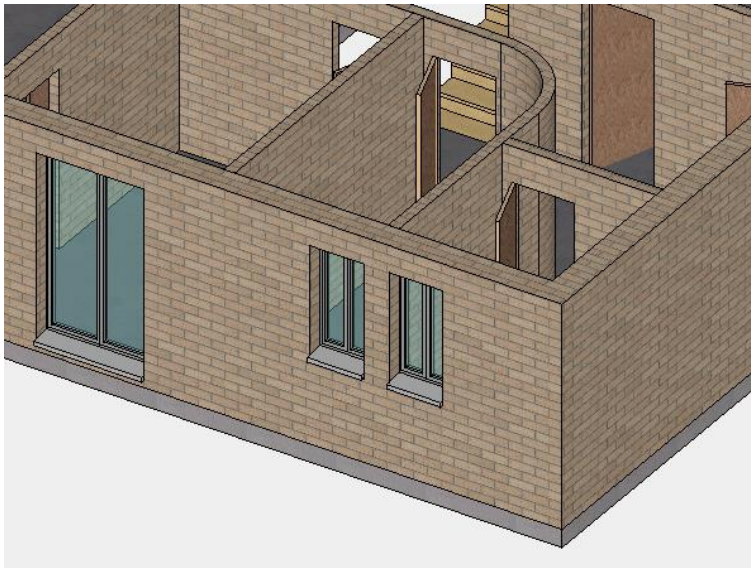

2. Now change the small windows to single-casement. Position the window.

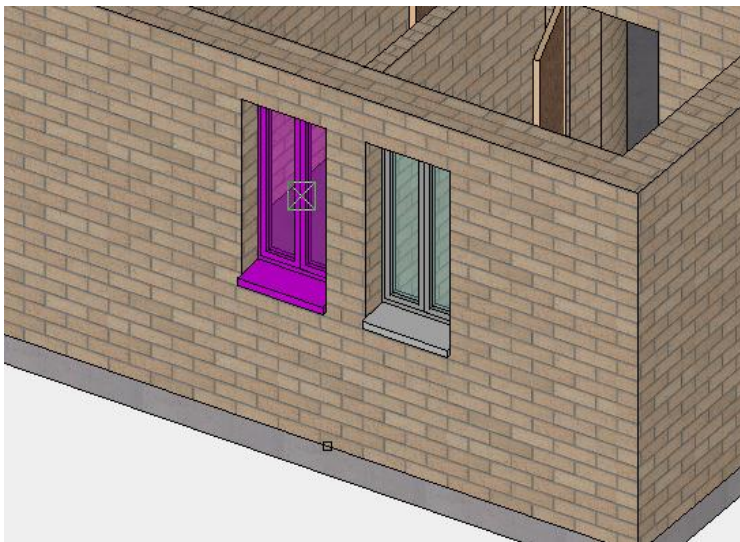

Open the *Tool for window casement/muntins* in the properties bar.

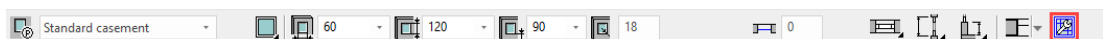

3. Select the function CASEMENT, change the OPENING SYMBOL and confirm with the function APPLY. Afterwards close the screen.

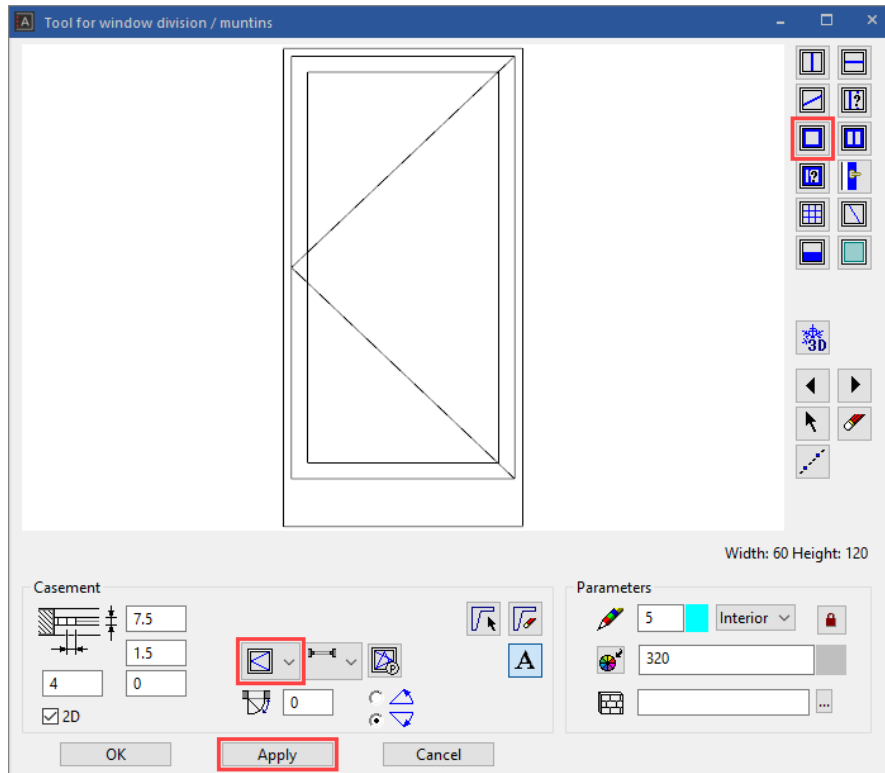

4. Proceed in the same way with the second window with changed opening situation.

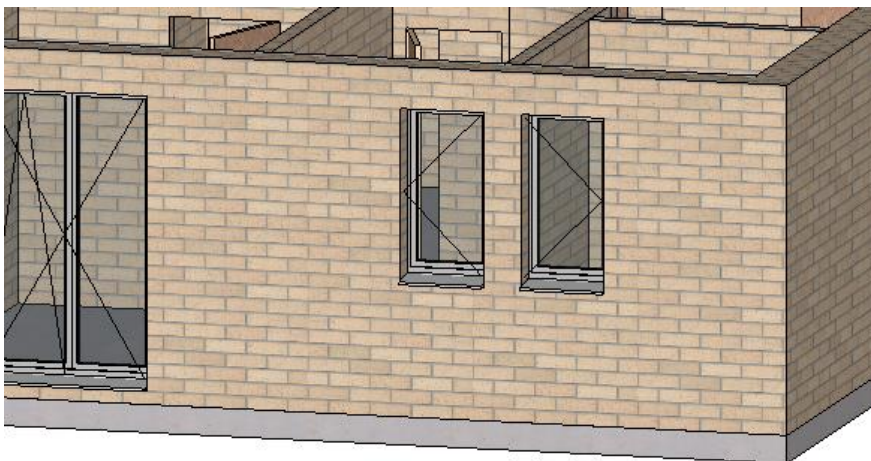

WORKSHOP END

MODIFY WINDOW PARAMETERS

The thresholds of the window doors are still represented as parapet windows. The inner sill must be removed and the window frame extended as far as the concrete floor (slab).



WORKSHOP

1. Select a window door in the model and open the window parameters.

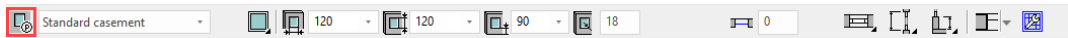

2. Switch to the detail parameter INNER SILL and switch off the 3D. If 2D and 3D is switched off in the display, the element is switched off and the remaining values do not affect the window.

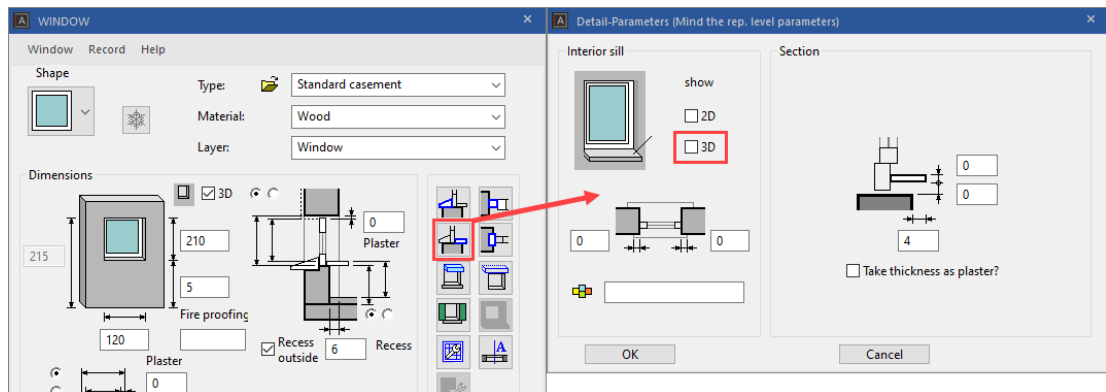

Close the mask of the detail parameter again and click APPLY in the window parameter mask to apply the change to the window on the model.

3. Change the niche depth to **6** cm. Switch to the detail parameter **OUTER SILL**. Top edge of window sill is +5 plus 10 cm floor finish. Add the values in the detail parameter (you will adjust the frame in a minute).

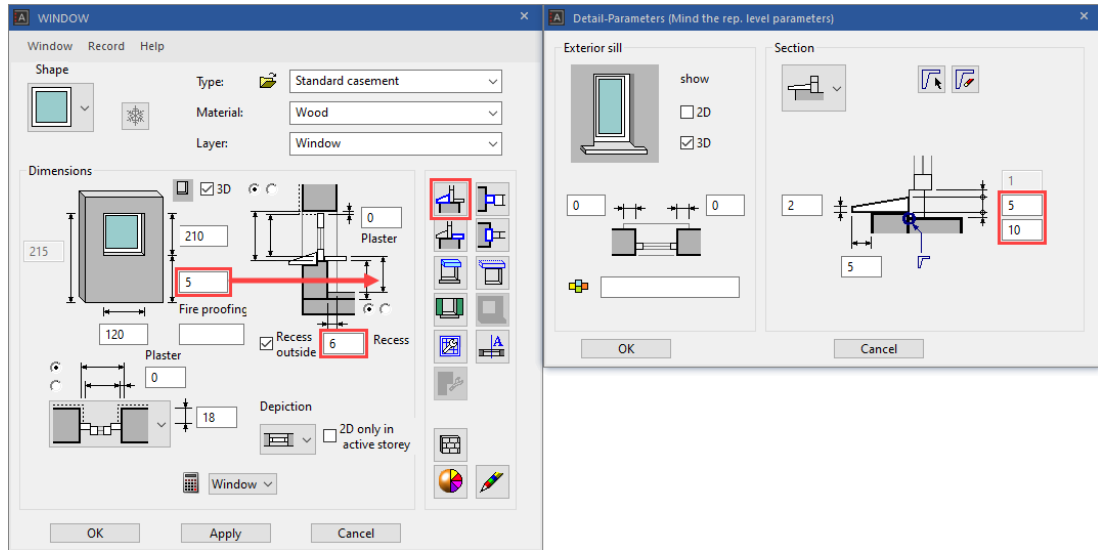

4. Switch to the detail parameter **W. FRAME PARAMETERS** and extend the base of the frame to **16** cm.

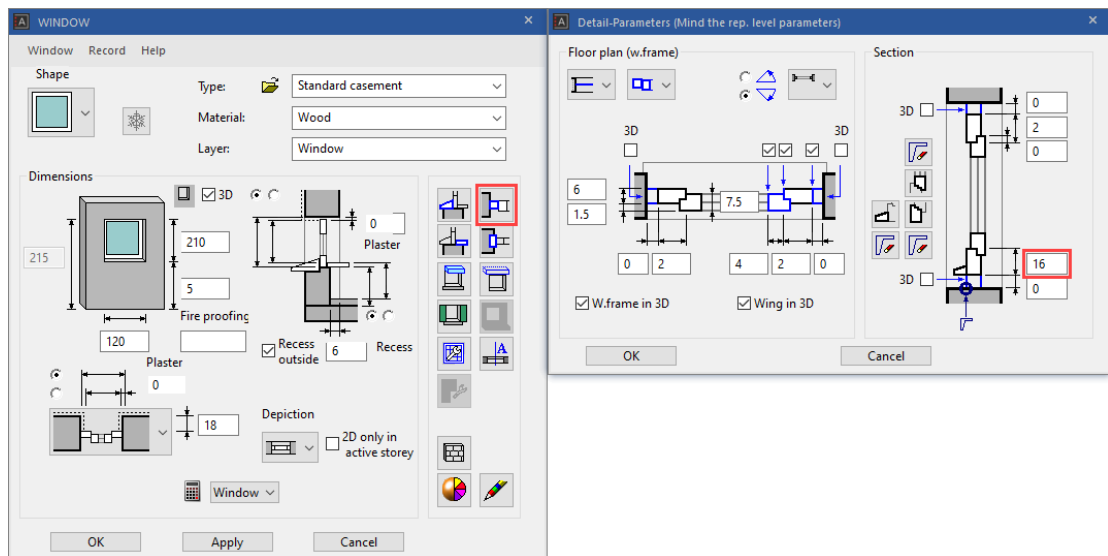

5. Close all screens and check the window.



6. These settings must be transferred to all window doors. Use the function TRANSFER PARAMETERS and select the corrected window.



7. Extend the screen with the selection (1) since the change is only to apply to the window doors. The window doors have a height of 205 as main feature. Select the height alone (2,3) and trigger the selection (4). The selection screen closes and you can apply the change to all (5).

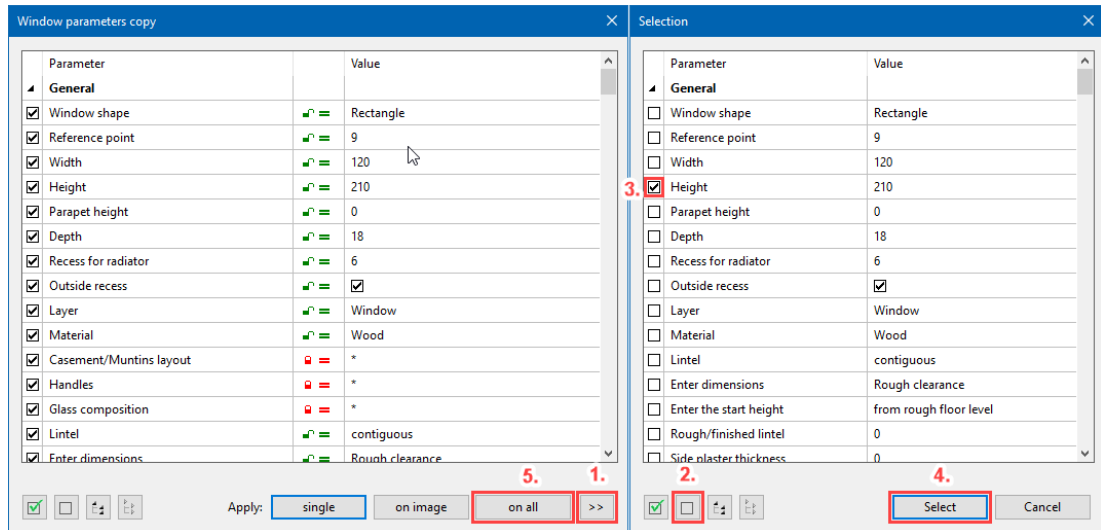

8. Switch back to the start position current zoom [Ctrl]+[spacebar] and into the wire model [Ctrl]+[D].

STAIRS

Various stair types are parameterised and can be entered on graphical screens.

WORKSHOP

Create a dog-leg concrete stair with a landing.

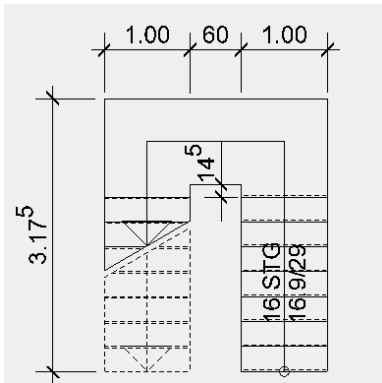

1. Open the stair mask.



2. Select the type "concrete stair".



Select dog-leg stair



3. Check whether the height (storey) reference is set.



Value **G** is automatically the storey height, the gradient is calculated.

Change the number of steps to alter the gradient.

4. Switch the limit value parameters to *No optimizing*.



5. Enter the rest of the values in the mask.

6. Fix the length for value **C + E**

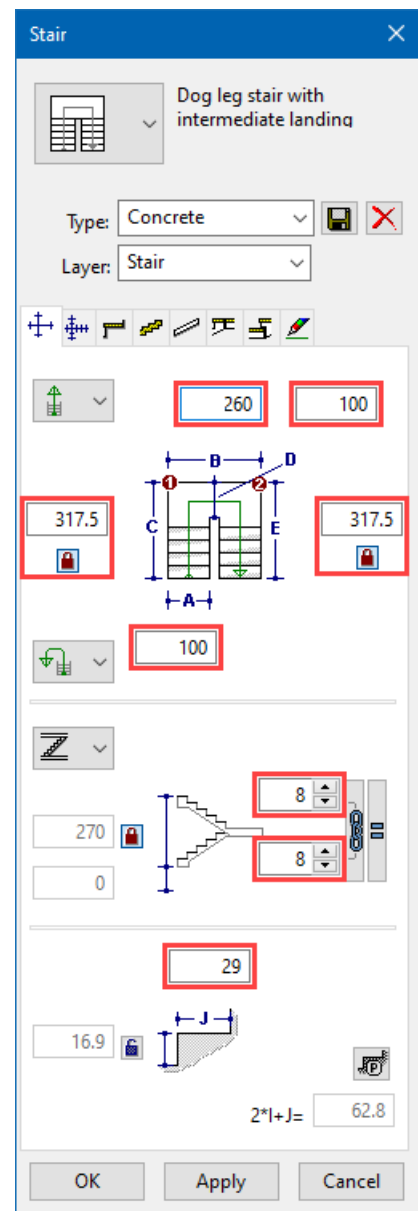

7. Select "Landing and step winding"



Check the alignment of the exit and entrance. If the stair lengths are fixed, the values in the mask are locked.

Change the gauge of the podium to 20 cm.

8. Select step design



Enter the values for the covering

9. Select stringer



Switch off stringer

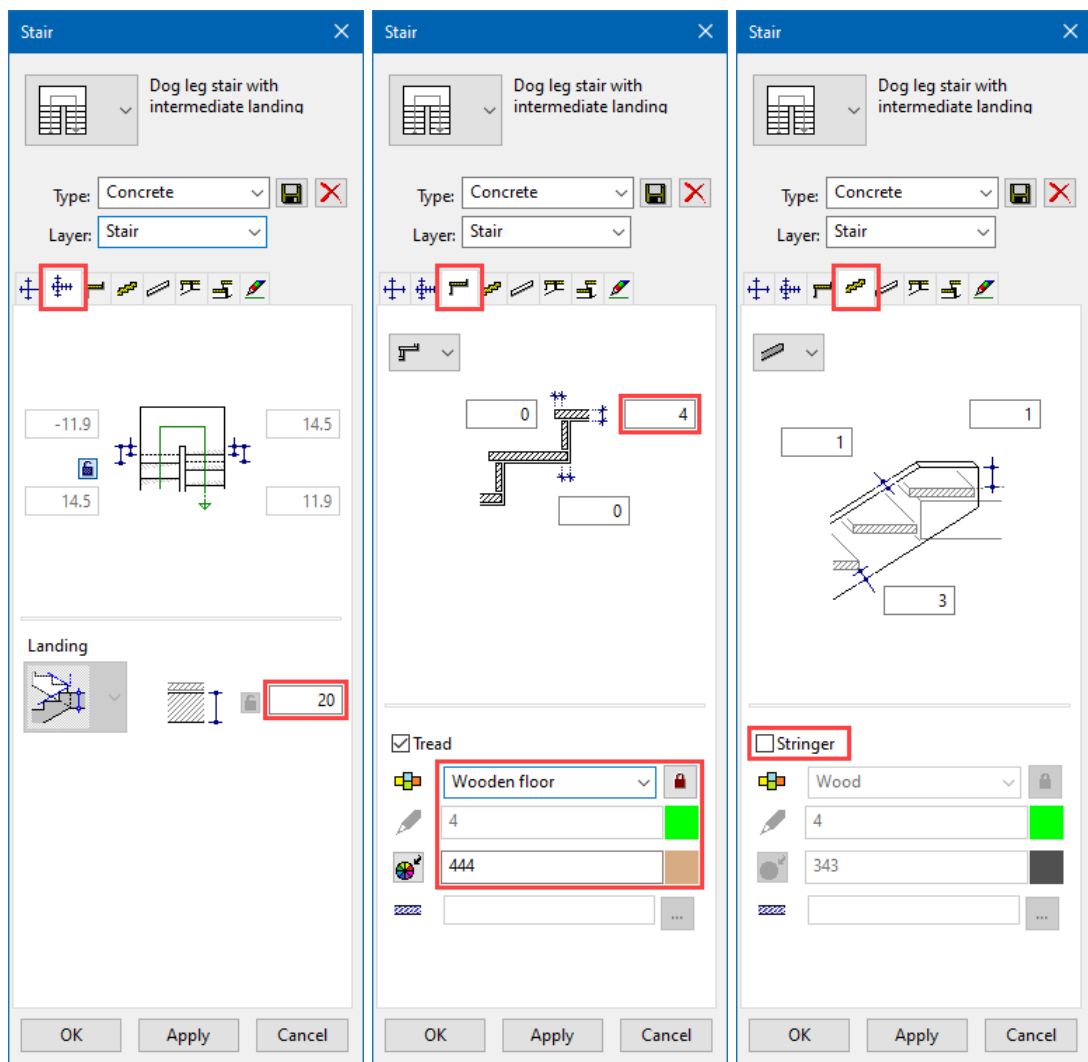

10. Select load-bearing construction



Enter gauge of construction

11. Select stair head



Select exit type and set exit length to 29 cm

12. Select stair foot



Select entrance type and set entrance length to 29 cm

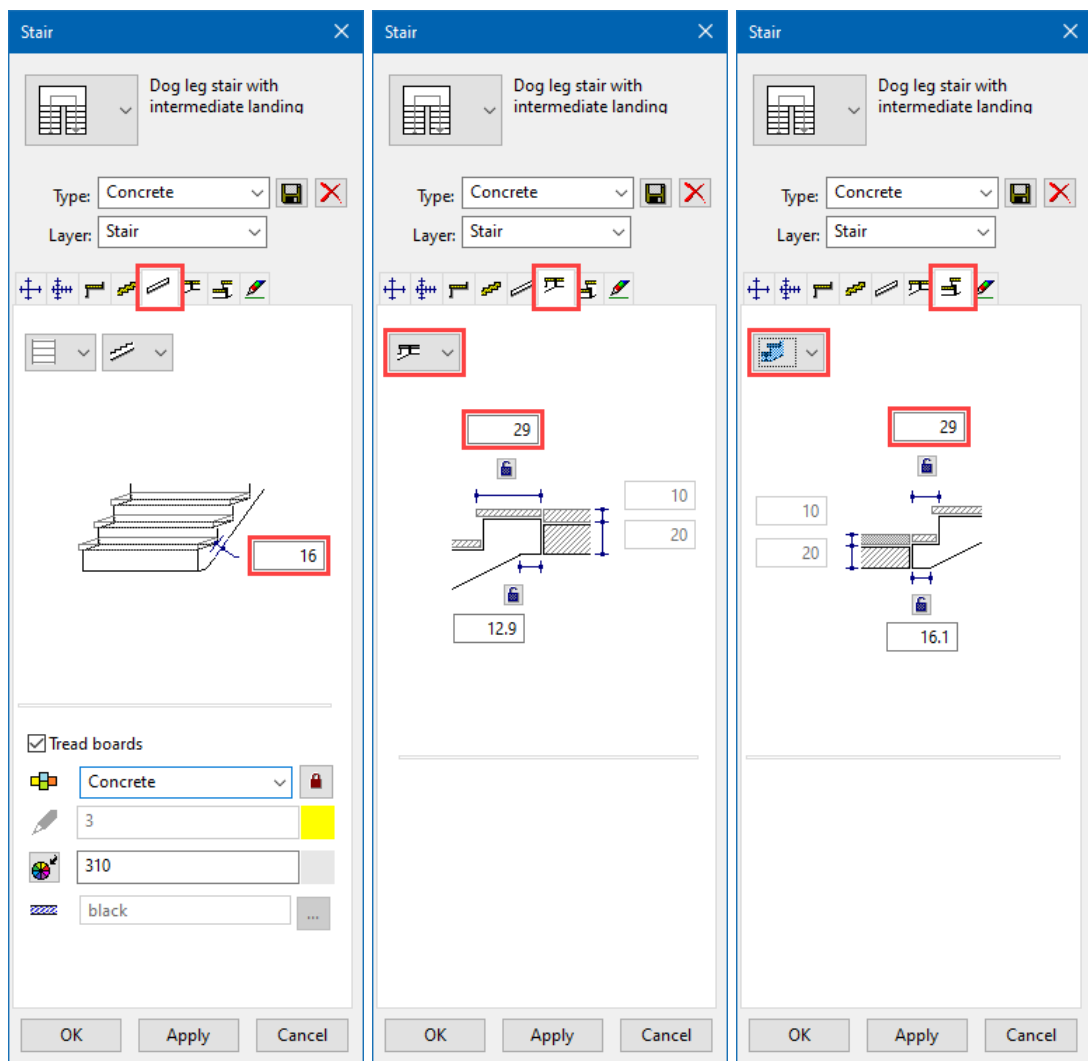

13. Plan graphics of stair



Floor plan depiction "Top view of lower stair"
 Activate floor plan depiction for upper storey

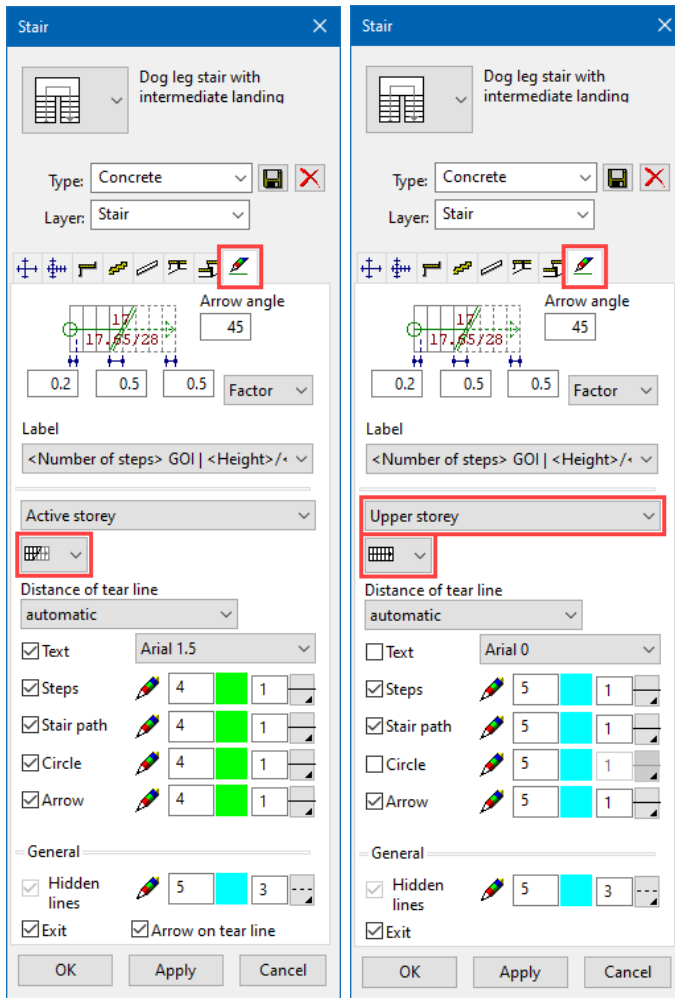

14. Position stair in model

first point > **P1**; second point > **P2**; placement type > **P3**

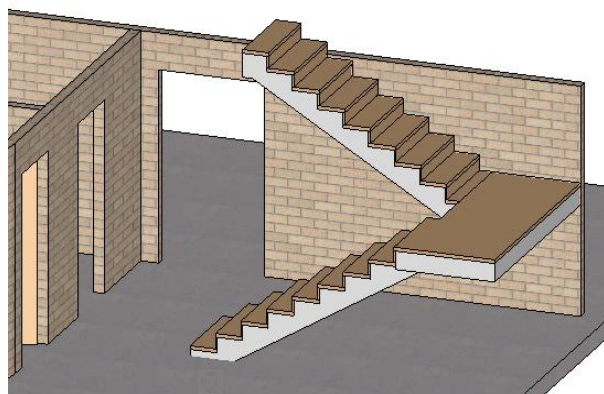
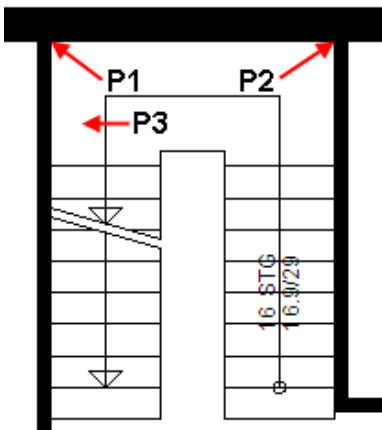

Click OK to close the screen.

EXPLANATION

On the geometry tab you can see the two points by which the staircase is to be placed.

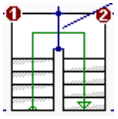

WORKSHOP END

STRETCH

In addition to the stretch function, the construction parts, elements and hatches can also be stretched using their handles.

▼ ▼ ▼ ▼ WORKSHOP

The wall must be stretched in such a way that the wall corner is flush with the staircase entrance.

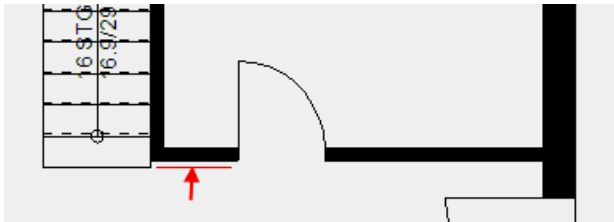

1. Select the wall. The wall turns magenta and handles appear on the axis. In addition to the handles, the wall can also be changed on the axes marked by a dotted line, the grippers.
2. Click in the corner on the axis (cursor symbol switches to double-arrow) **P2**. In the input assistant select the manipulation function MOVE ELEMENTS PARALLEL.



3. Set a temporary reference point **RP** at the corner of the stair and move the cursor vertically below the point on which you selected the axis. Orthogonal help lines are created starting from both points on the section point of which you can set down the wall.

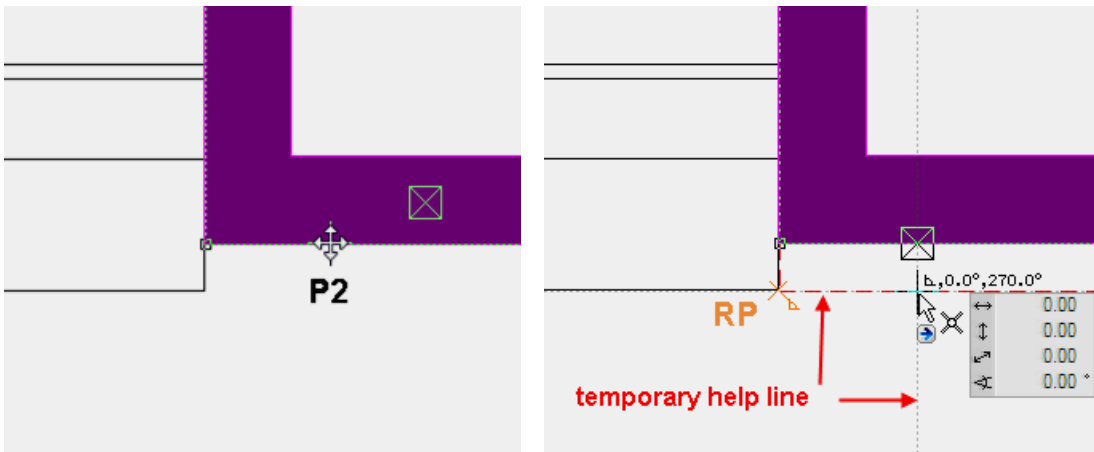

4. Cancel the function with [**Esc**].

WORKSHOP END

STAIRCASE OPENING IN GROUND FLOOR SLAB

There are a number of different ways in which the shape of a slab can be modified.

- Manipulation functions in the Input Assistant, applied to the slab contour
Used mainly for changes to the outer contour



- Change functions in the properties bar
Edit slab contour or split slab



WORKSHOP

The ground floor slab is to be cut out in the stair area. The new contour of the slab must match the red line. A help line is created in this example as an aid to design. Equally, you can work just as well with the temporary reference point.

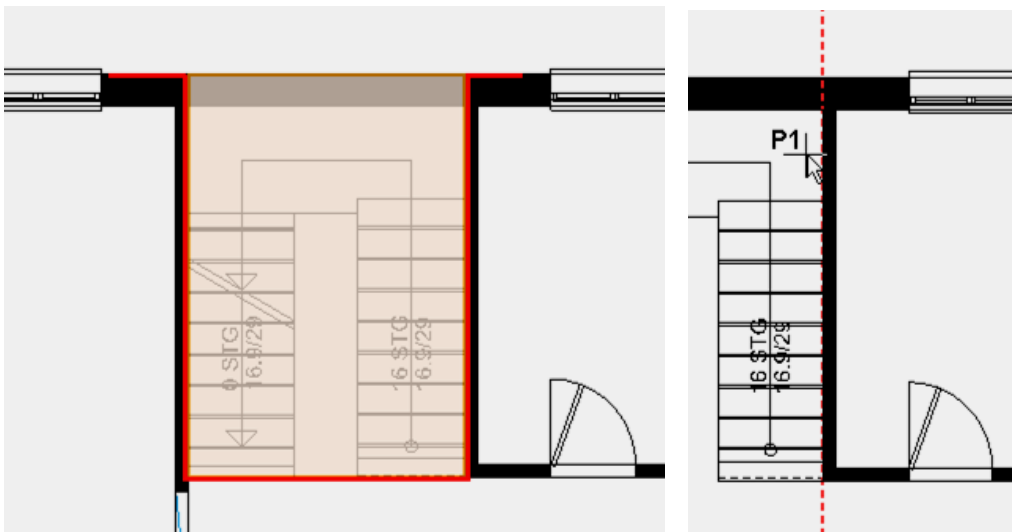

1. Apply a help line using the function PARALLEL STRAIGHTS with distance 0 to the staircase wall **P1**.



2. Select the slab by clicking on the outer edge of the wall below which the slab contour is also located. The selection window with the number of options will be displayed. Use the arrows to switch between the selections. Select the slab.

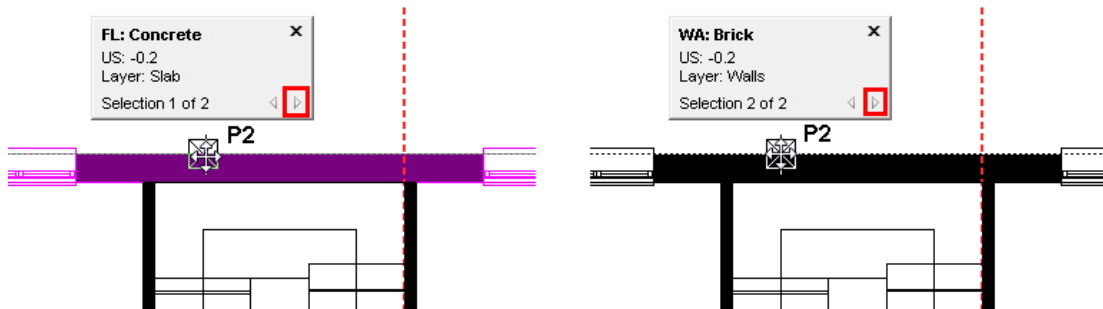

3. Click again on the contour **P2** so that the input assistant appears. Select the function REDUCE POLYGON.



The input assistant switches to the drawing functions. Select the function RECTANGLE.



Drag the rectangle up to the points **P3** and **P4**.

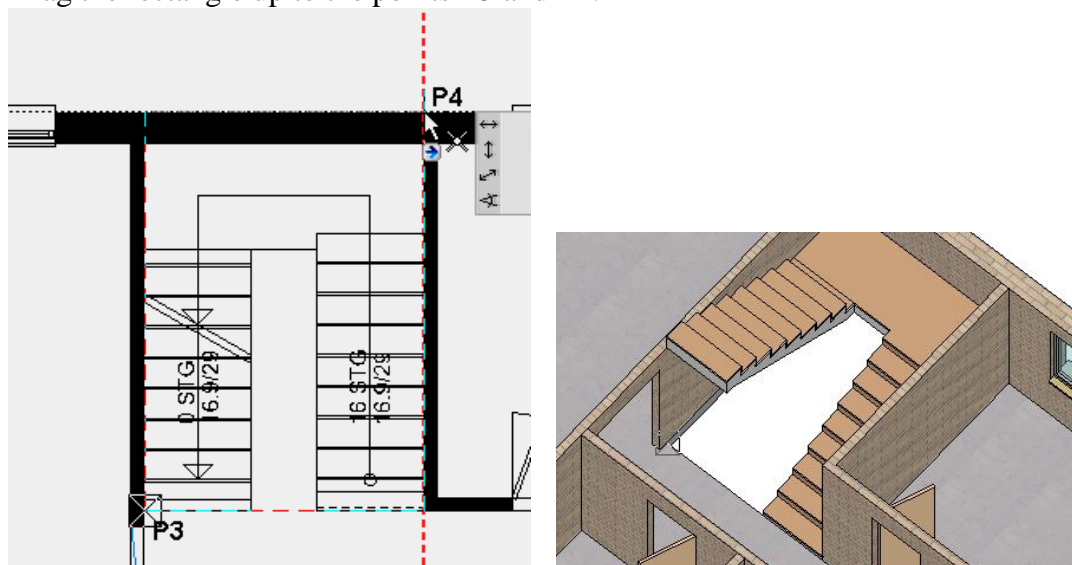

4. To check, switch to the solid design model and then back to the wire model

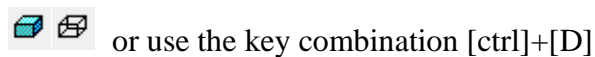

or use the key combination [ctrl]+[D]

WORKSHOP END

TOP FLOOR SLAB

▼ ▼ ▼ ▼ WORKSHOP

1. Select the top floor as current storey.

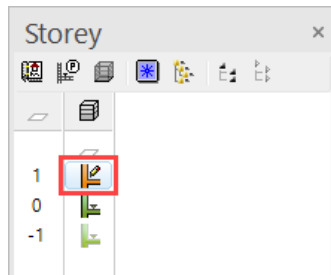

2. Select the function CREATE SLAB.



3. Access the type *Standard* and if necessary change the type of entry to *Draw contour manually*.

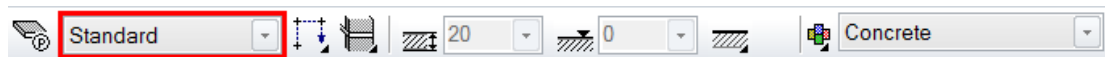

4. In the Input Assistant, the drawing function POLYGON active is selected as standard. Run along the contour shown in red.

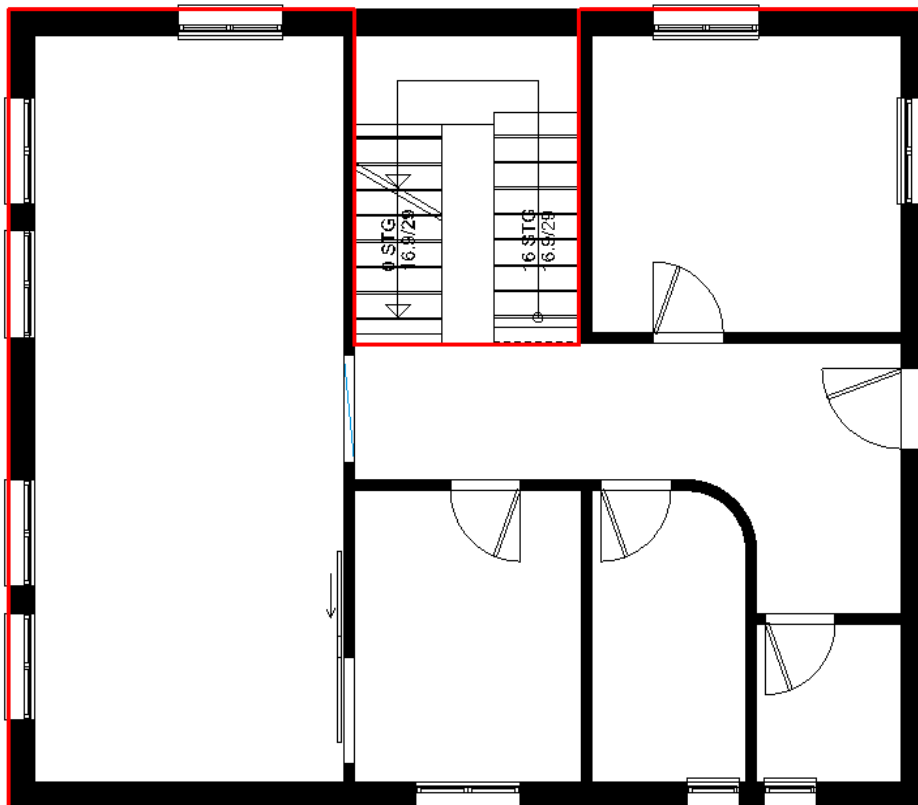

5. Cancel the function with [Esc].

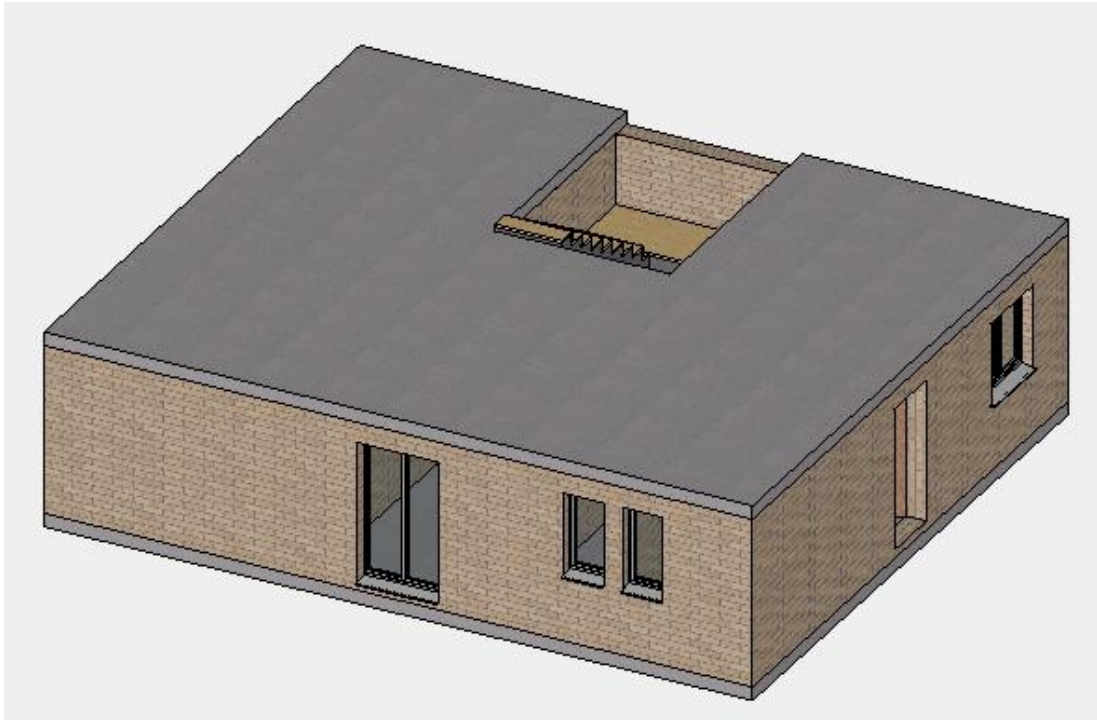

WORKSHOP END

WALLS / DOORS TOP FLOOR

The visibility of storeys is set in Storeys Manager. From the context menu (right-click) for the individual storeys you can switch between visible and invisible.

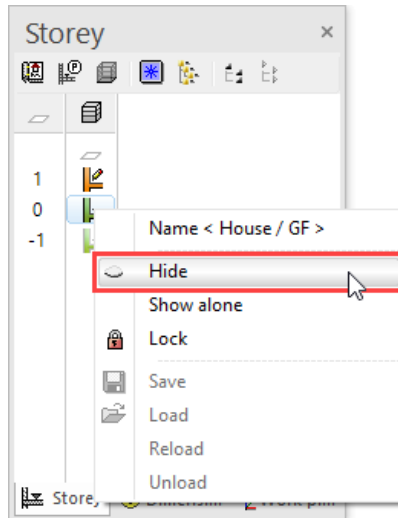

Inner walls must not cross! This leads to errors in the room calculation. Stop the second wall and start a new wall on the opposite side.

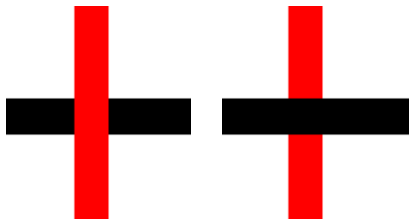

▼ ▼ ▼ ▼ WORKSHOP

You've already got enough experience with drawing to be able to create the walls and doors on the top floor by yourself.

1. Draw the top floor walls in accordance with the following figure.
2. Use the same settings as in the ground floor for the doors in the top floor.
3. For the sake of clarity, the ground floor can be switched to invisible or visible again. To do so right-click on the ground floor and select the appropriate option.

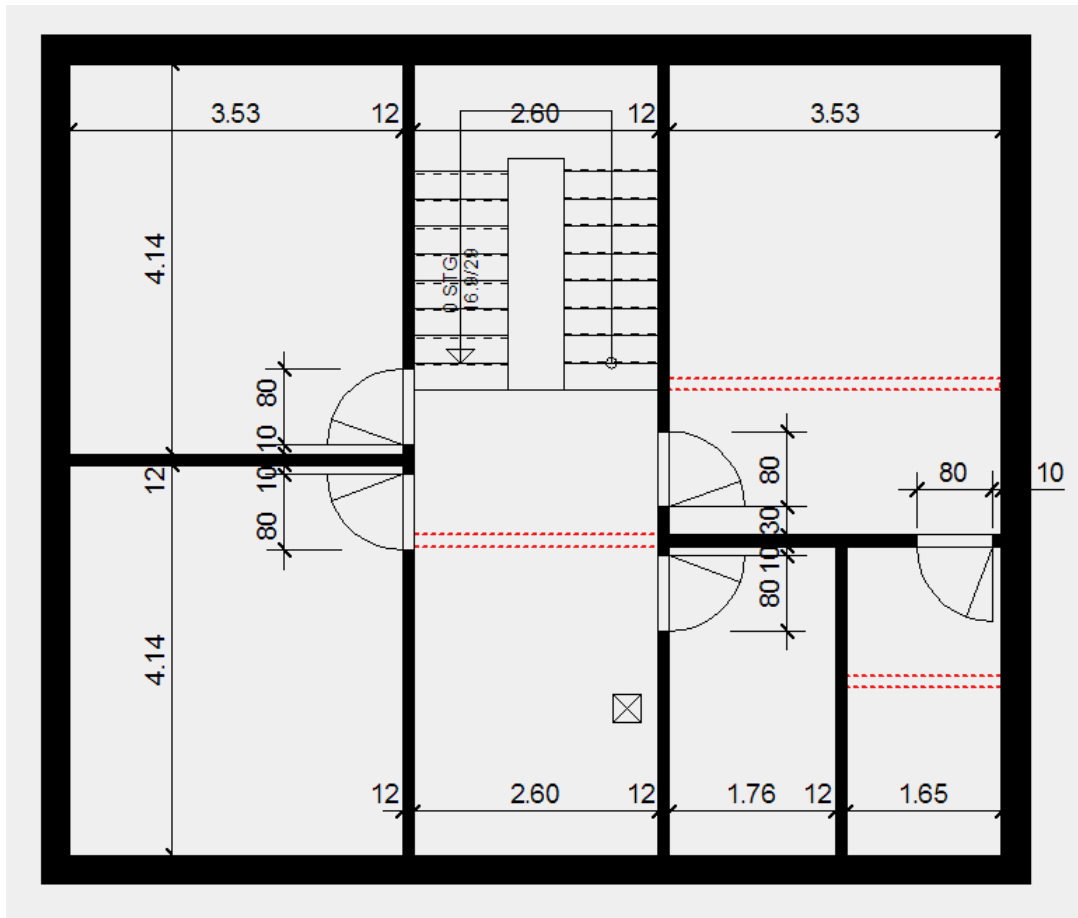

Red dotted lines = walls in ground floor

Outer wall



Inner walls



Doors

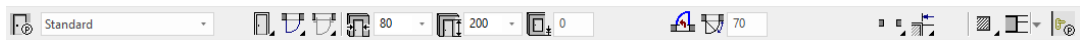

WORKSHOP END

COPY INTO ACTIVE STOREY

Some building components are the same in different storeys. Construction parts can be copied to other storeys and then changed if necessary.

The inner walls of the basement storey are arranged in a similar way to those on the top floor.

▼ ▼ ▼ ▼ WORKSHOP

1. Select the basement as current storey.

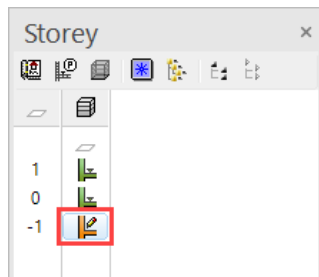

2. Select the function COPY INTO ACTIVE STOREY.



3. Switch to the solid model [Ctrl]+[D] and rotate the model in 3D.

4. Copy the objects to the basement.

Select the exterior wall **P1**, the inner walls **P2-4**, and the stair **P5**, to copy the relevant elements to the basement.

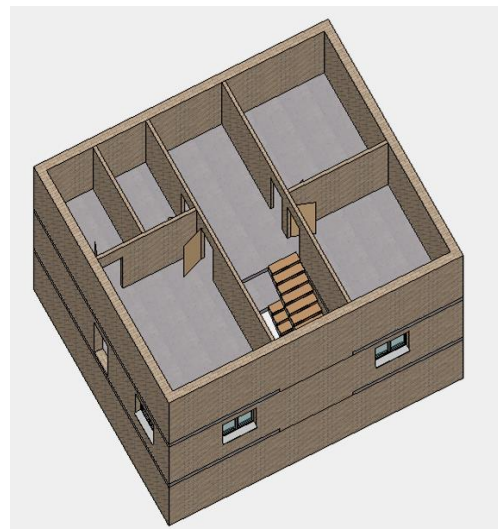
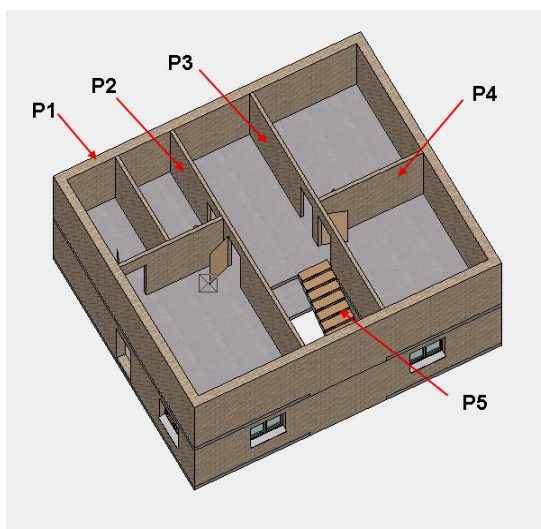

WORKSHOP END

EDIT / DELETE AN OBJECT

▼ ▼ ▼ ▼ WORKSHOP

The wall thickness of the outside wall in the basement must be corrected to **25** cm and the material changed to concrete.

1. Switch only the basement to visible.
Double-click on "BA".

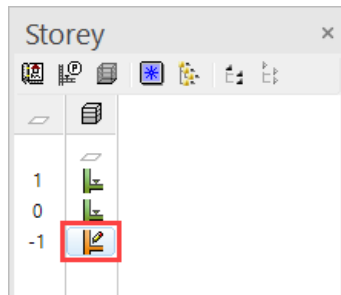

2. If you click on the outer wall, in the properties bar switch to the type *Concrete* and set the wall thickness to **25** cm.



3. The wall thickness must be retained in the zone near the staircase. So that a different wall thickness can be assigned to one part of the wall, the wall must be divided in this area.

Under the change functions, select the function **DIVIDE WALL** at the end of the properties bar.



Since this is a closed wall, two partition points must be specified. For the partition points click on the points **P1** and **P2**.

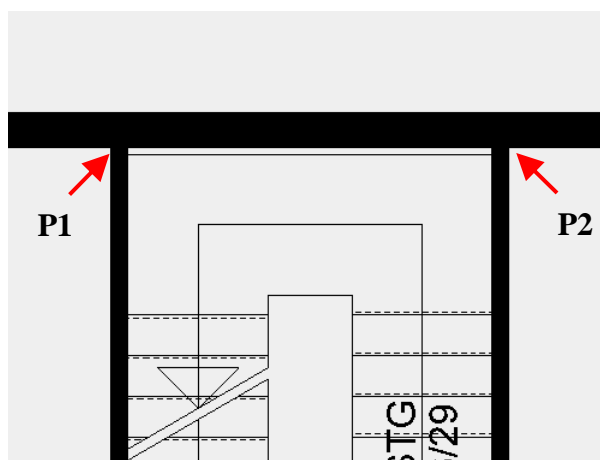

4. Now click the new wall section and set the wall thickness back to 30 cm.

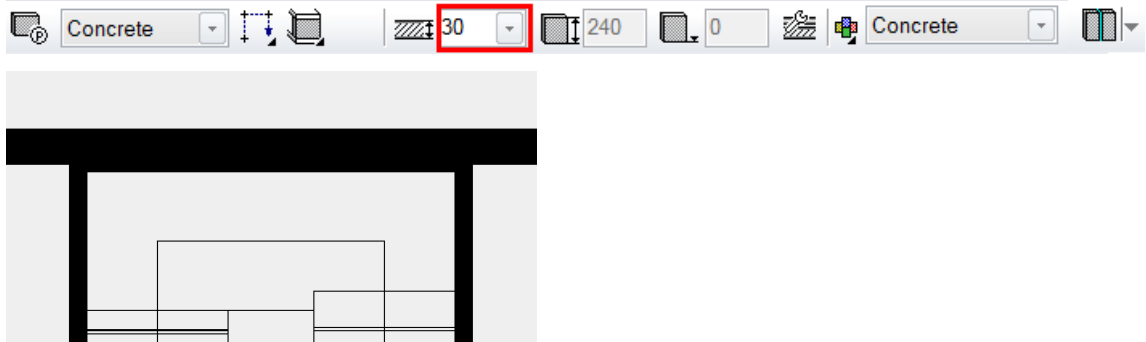

5. Cancel the function with [Esc].

6. You copied the basement staircase from the ground floor. The connections and plan graphics must be adjusted to the storey.

Double-click on the staircase to open the stair mask. Make the various settings.

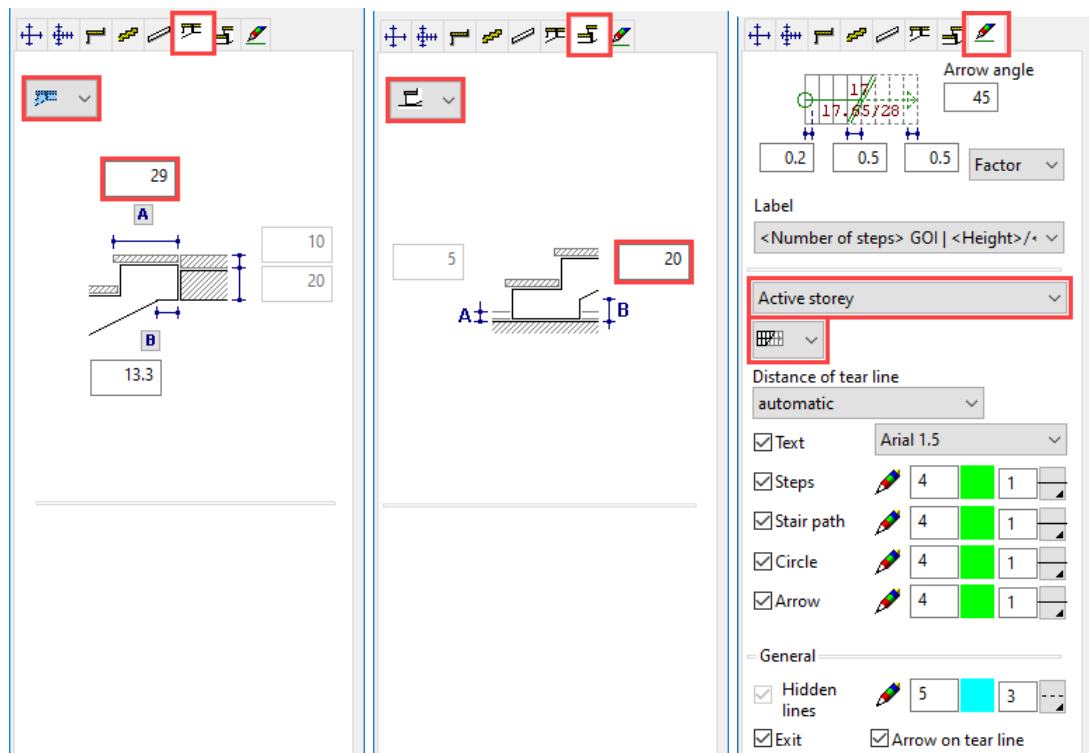

Display in model

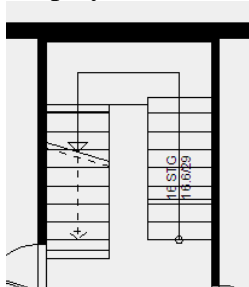

Display in 2D plan

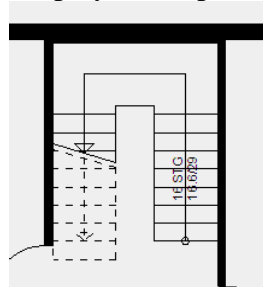

7. Delete one of the two basement doors. Select the doors and delete them using the DELETE function or the [Delete] key.

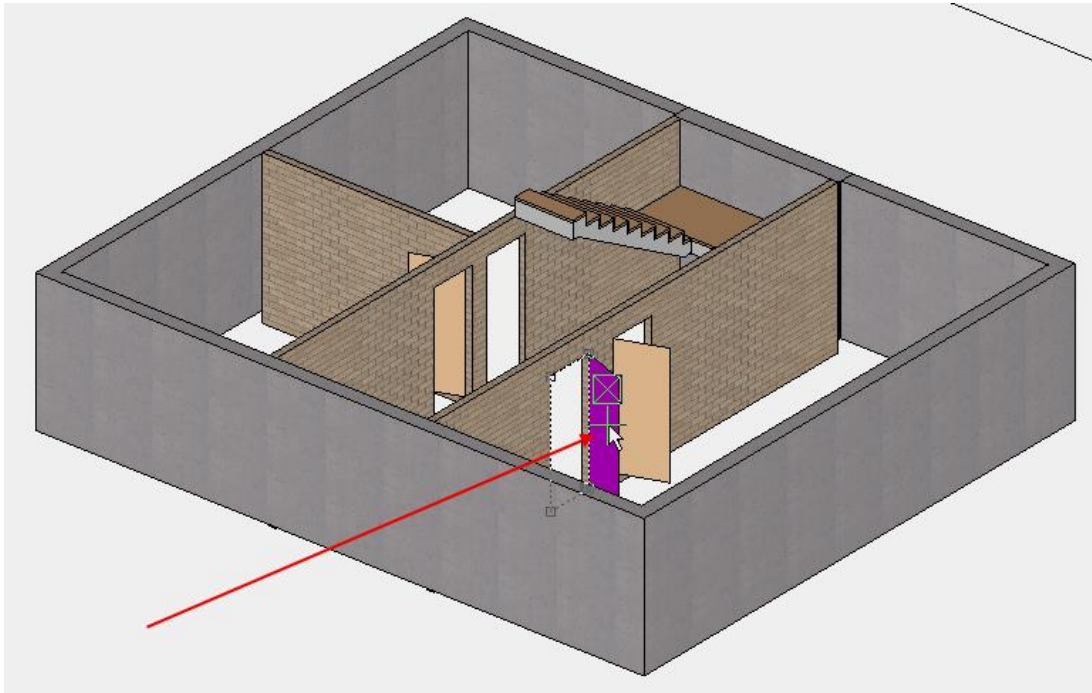

8. Delete selection > YES.

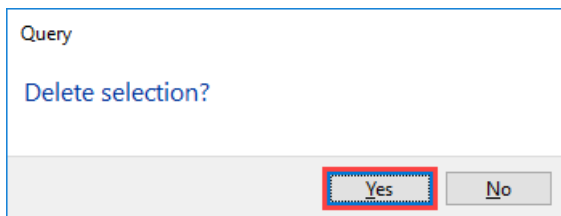

The delete confirmation can be disabled in the options.

WORKSHOP END

FOUNDATION SLAB WITH PROJECTION

▼ ▼ ▼ ▼ WORKSHOP

The basement must be supplemented with the slab, the garage door and the basement windows.

1. Switch back to the wire model **[Ctrl]+[D]** and to the starting position **[Ctrl]+[Spacebar]**.
2. Select the function CREATE SLAB.



3. Switch to the type *Foundation*. This type has the attribute *Foundation slab*.



4. The drawing functions appear in the Input Assistant. Switch to the drawing function RECTANGLE.



5. Expand the rectangle so that it extends over the points **P1** and **P2**.

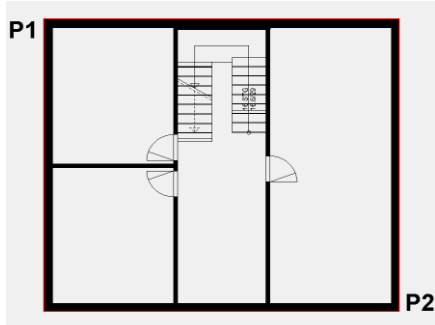

6. Cancel the function with **[Esc]**.

7. Select the slab just drawn. If the selection prompt appears, switch to the slab.

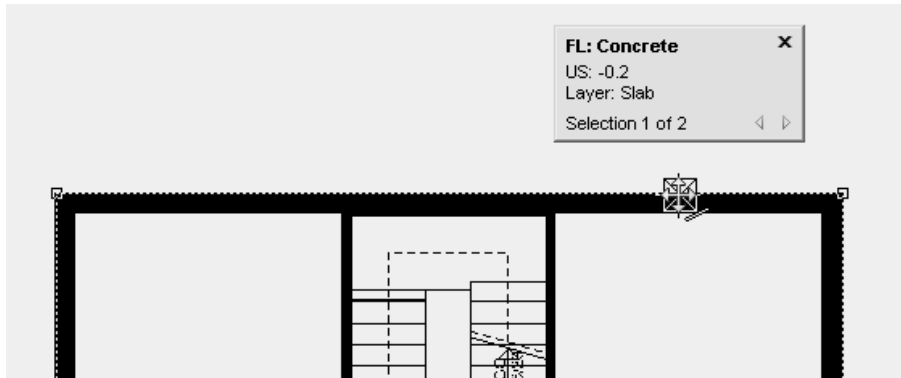

8. Click again on the contour **P1** so that the input assistant appears and select the manipulation function **MOVE ALL ELEMENTS PARALLEL**. Move the cursor vertically over the marking point **P1** and enter the distance of **10** cm.

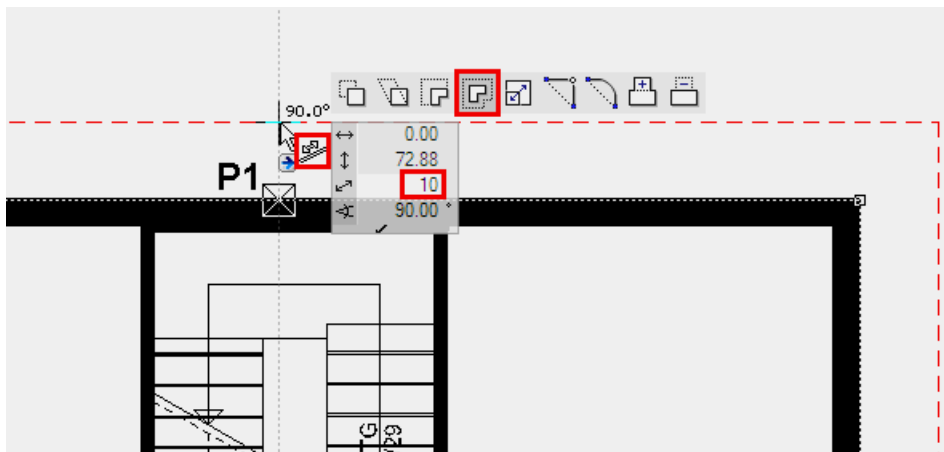

9. Cancel the function with **[Esc]**.

10. The right-hand part of the basement is a garage. Draw the triangle garage door with the following settings.



11. The last thing to do is to add the basement windows to the basement floor plan. The dimensions can be seen on the plan below.

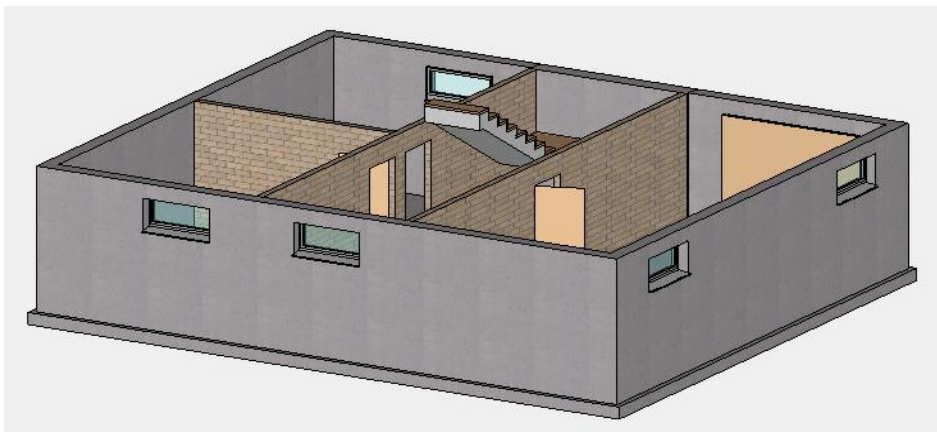
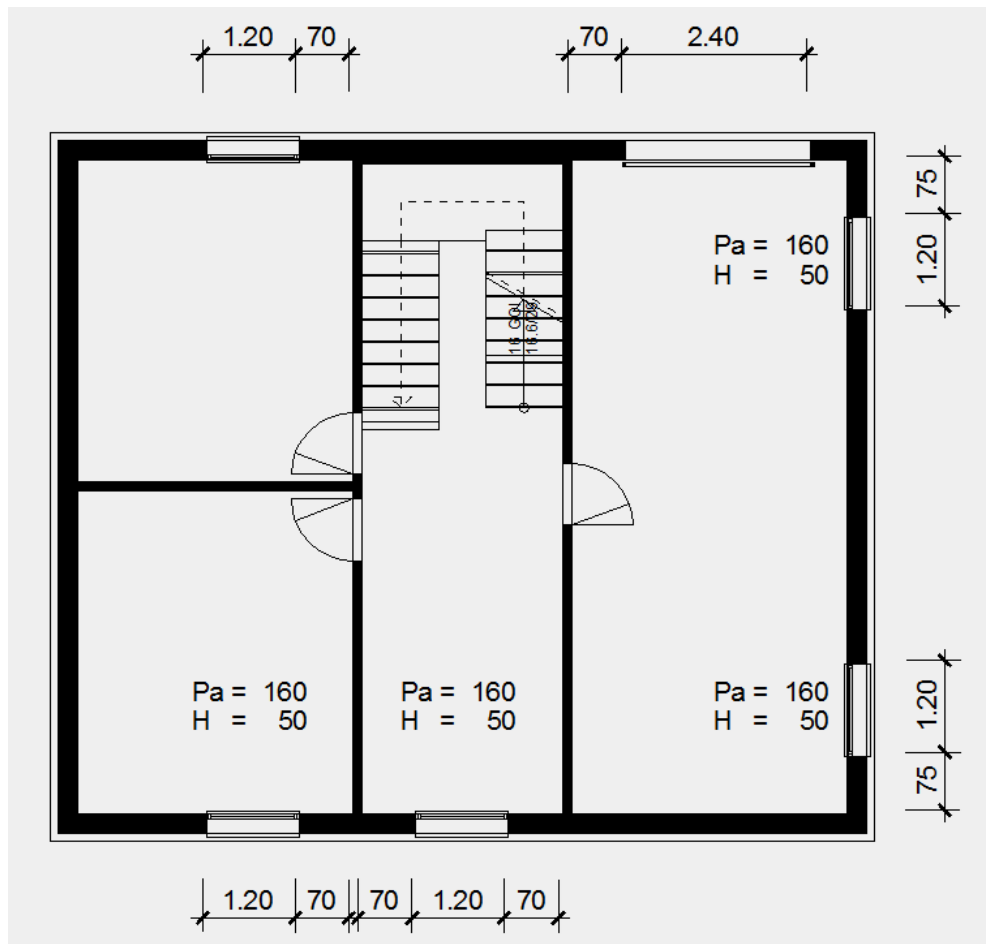

WORKSHOP END

ROOF

WORKSHOP

1. Select the top floor. Double-click

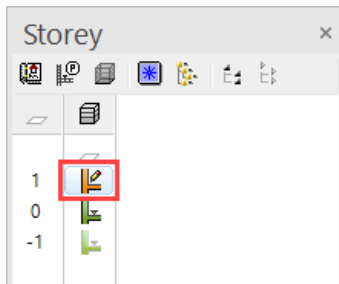

2. Create help lines to construct the roof overhang. Vertical 30 cm; Horizontal 70 cm

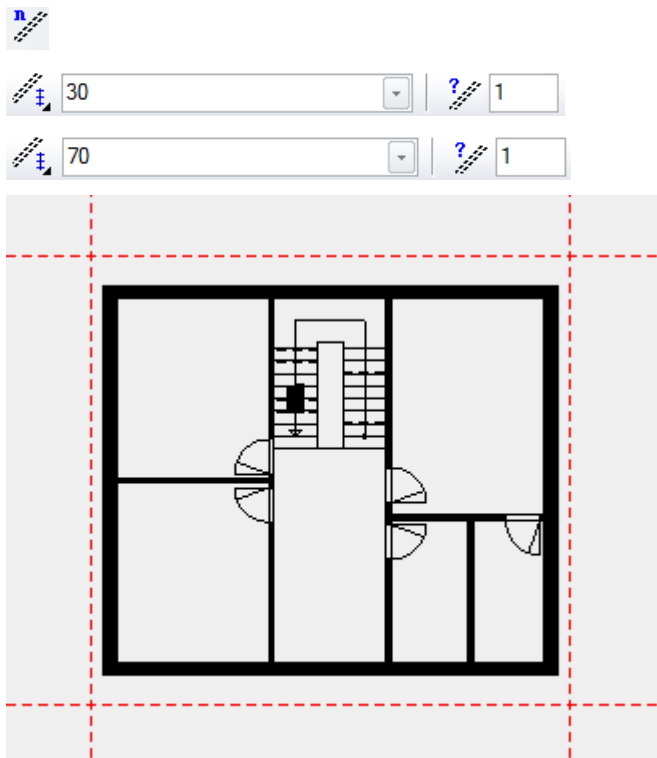

3. Select the function CREATE ROOF and open the roof parameters in the properties bar.

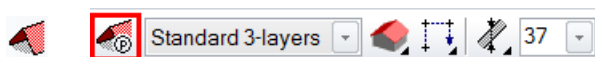

4. Set the parameter in accordance with the template.

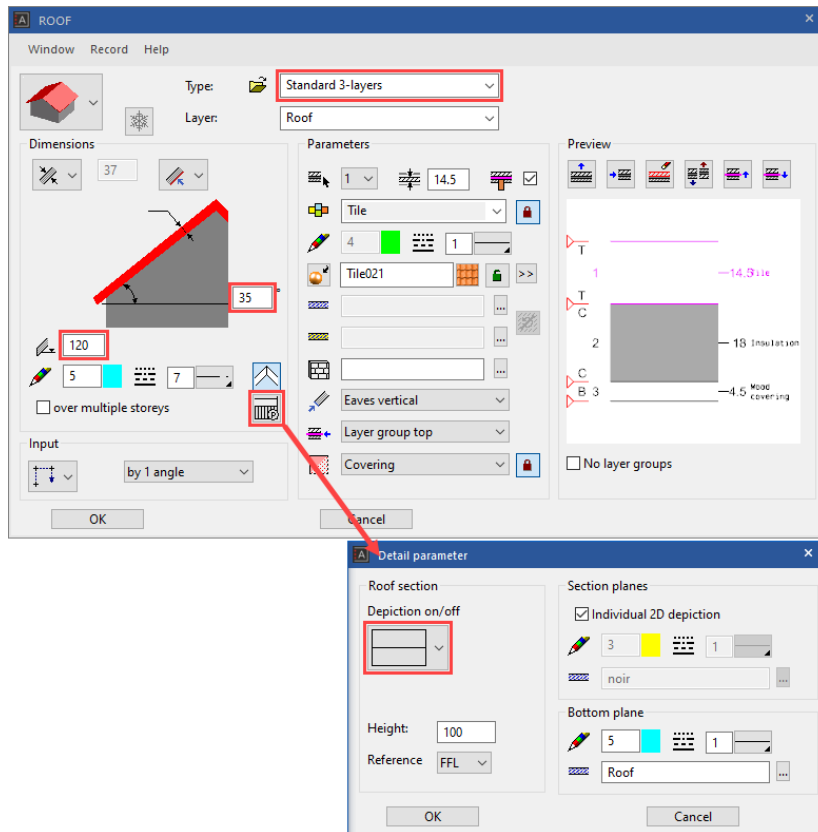

5. The drawing functions appear in the Input Assistant. Switch to the drawing function RECTANGLE and increase the size of the rectangle.



6. Next, set the ridge points.

Move the cursor to the centre of the vertical edge until the snap symbol switches to *Middle of element*. Set the first ridge point. For the second ridge point, move the cursor horizontally into the structure and click.

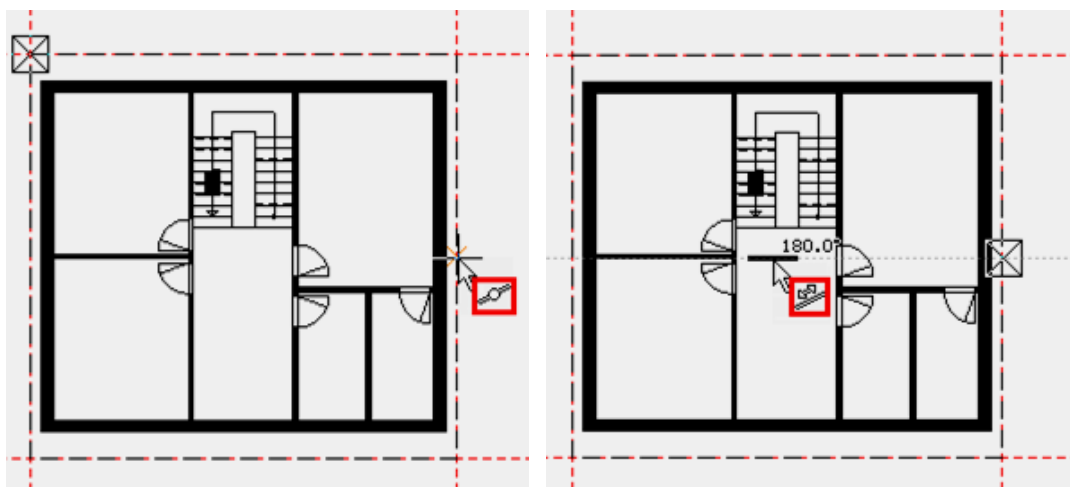

7. The last entry is the point to which the height must be transferred. In this example it is at the bottom left on the inside of the jamb wall.

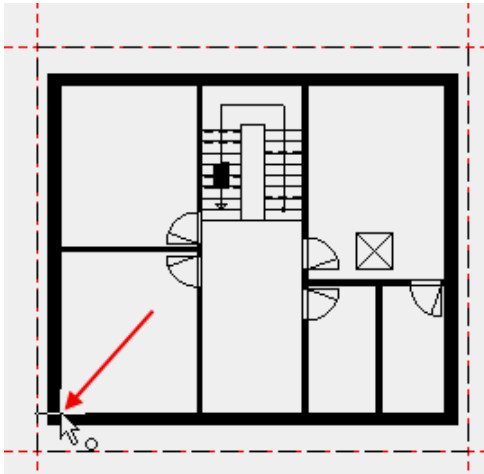

8. Cancel the function with [Esc] and delete the help lines using the function DELETE ALL HELP LINES.



9. Save a work copy [Ctrl]+[W].

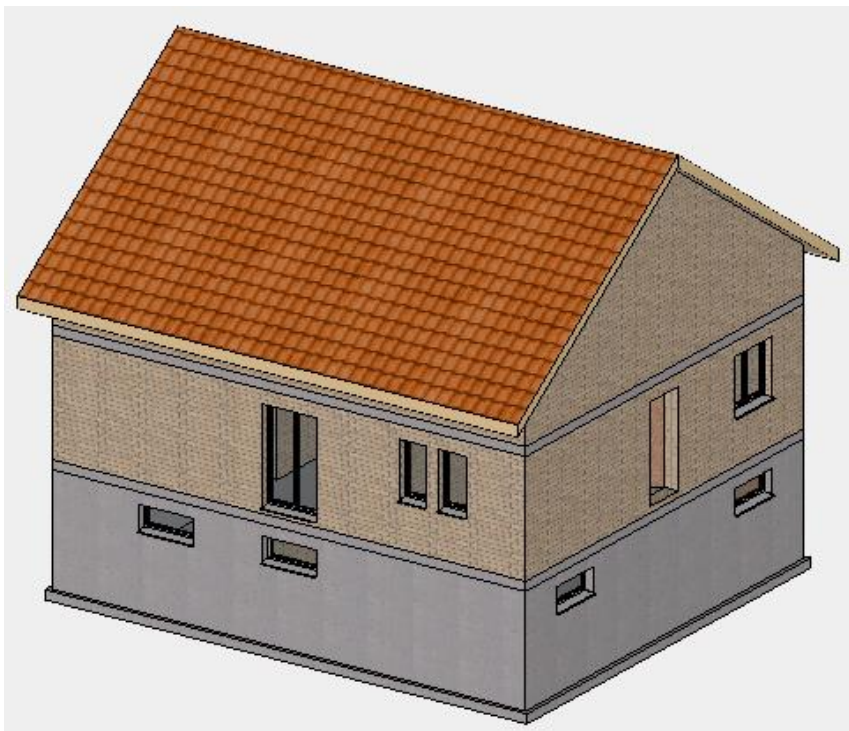

WORKSHOP END

WORK PLANE ON SURFACE

With ELITECAD you can set the windows both in the floor plan and in the view. The working level can be rotated as required or be set on planes.

However, working on a wall surface soon becomes messy if the entire model is visible. For the sake of clarity, when working in the floor plan you can hide storeys.

When working in the view the function CLIPPING is a useful tool for modifying the area of visibility.

▼ ▼ ▼ ▼ WORKSHOP

To enable a window to be set directly in the façade, the work plane must be placed on the façade.

1. Select the ground floor as current storey.

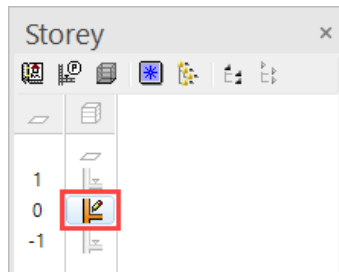

2. Set the work plane with the function WORK PLAN ON LEVEL on the façade.



For point **P1**, click on the façade.

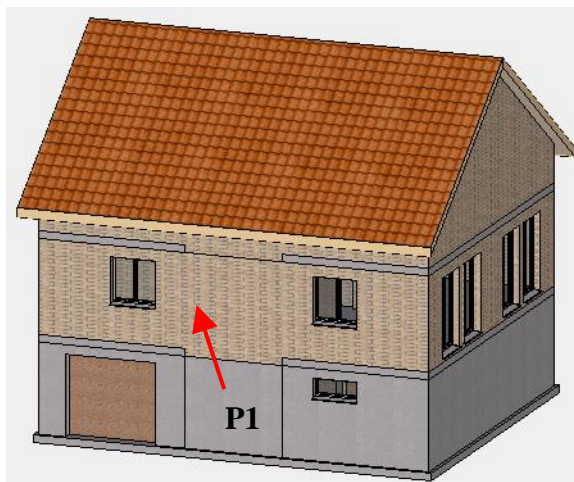

3. Switch CLIPPING on. On the clipping screen change the representation mode to 60 cm and activate it. The clipping planes can still be altered by dragging the yellow circles using the mouse.

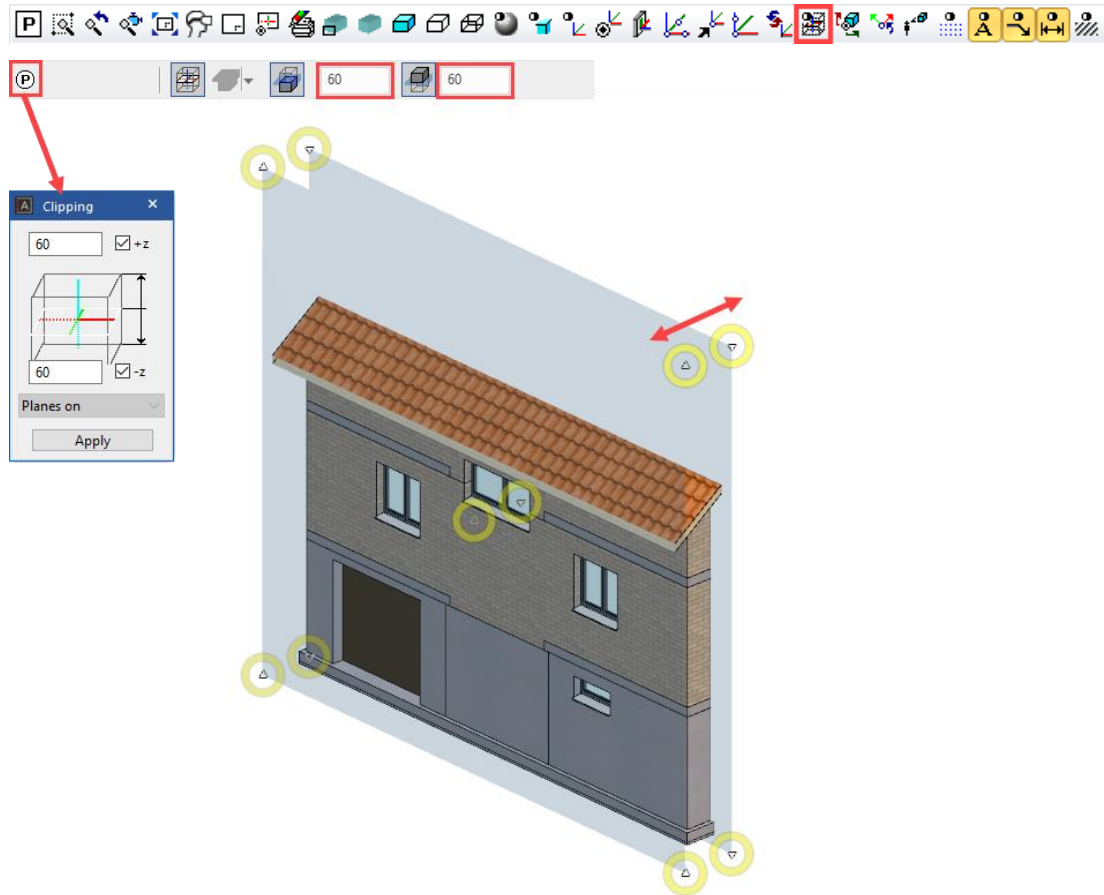

EXPLANATION

The clipping function can be used to reduce the visibility of the model.

In the Z direction (perpendicular to the work plane) the visibility is defined via distance information, e.g. 60 cm.

The data is only hidden on the screen. This means that the function cannot be used to create a view or section.

4. Set the work plane to perpendicular and switch to the wire model.
[Ctrl]+[Space bar], [Ctrl]+[D]

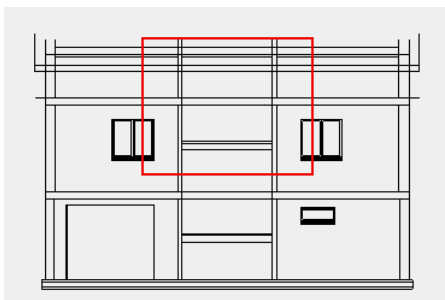

5. Zoom into the following image section.

Mouse wheel or [Shift] + centre mouse button, [Ctrl] + centre mouse button.

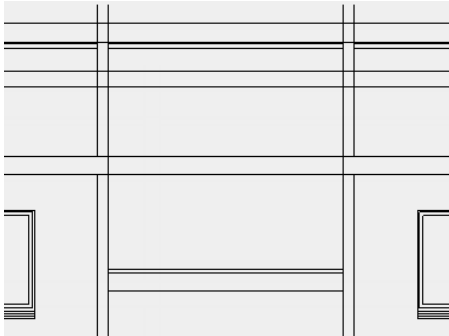

WORKSHOP END

SET WINDOW IN VIEW

If the wall reference is contiguous between multiple storeys, a window can be drawn that spans multiple storeys. The window appears in the floor plan of both storeys.

WORKSHOP

On the façade, set a window covering multiple storeys by increasing the size of the window in the façade.

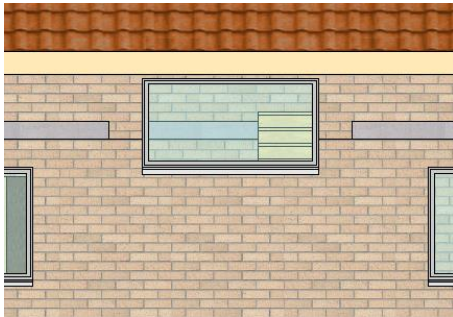

1. Draw help lines for the window.



A help line is created directly on the selected line with distance 0.



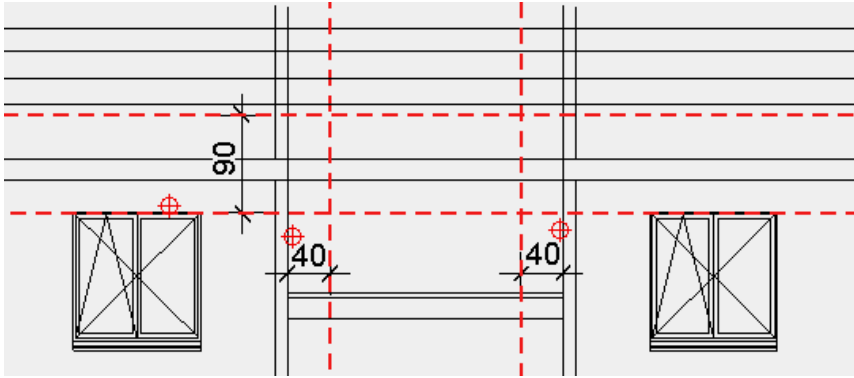

2. Position the window.
Open the window mask and make the selected settings.



3. Draw the window from bottom left **P1** to top right **P2**.

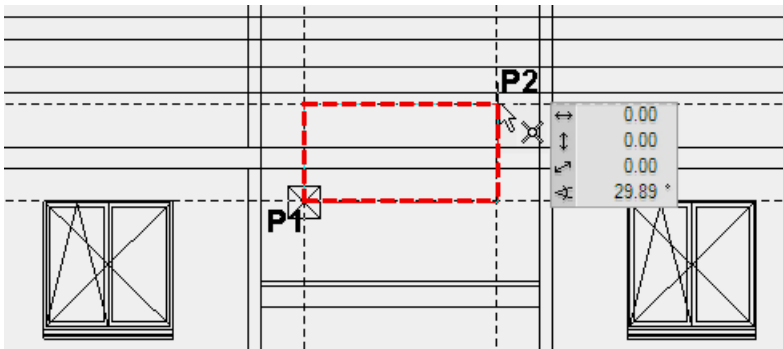

4. Cancel the function with [Esc].

5. Switch CLIPPING off.



6. Reset the work plane with the function RESET WORK PLANE.



7. Delete the help lines.





WORKSHOP END

WINDOWS IN TOP FLOOR

Like walls or slabs, windows can be copied individually to a current storey.

▼ ▼ ▼ ▼ WORKSHOP

Copy two windows of the ground floor to the top floor.

1. Switch to the solid model [Ctrl]+[D].
2. Select the top floor as current storey.

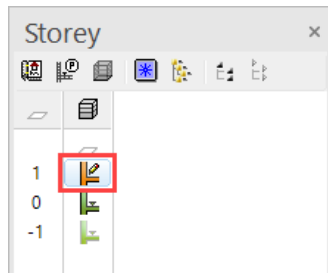

3. Rotate the model to the position shown below.
4. Start the function COPY TO CURRENT STOREY.



5. Click on the windows **P1** and **P2**.

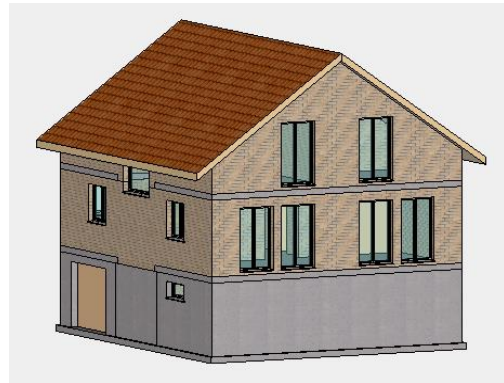
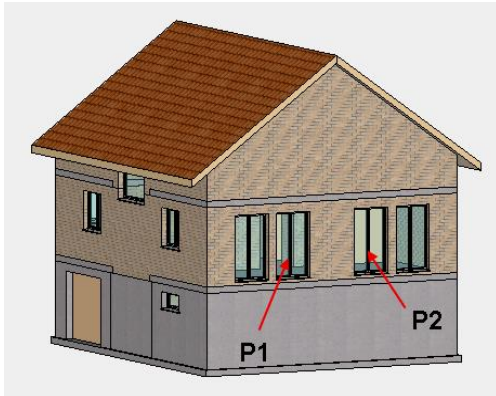

6. Switch back to the wire model [Ctrl]+[D].

WORKSHOP END

COPY/MIRROR WINDOWS

Instead of constantly having to reposition windows, existing windows can be copied and also rotated or mirrored.

WORKSHOP

1. Switch the top floor < > *visible alone*. (double-click)

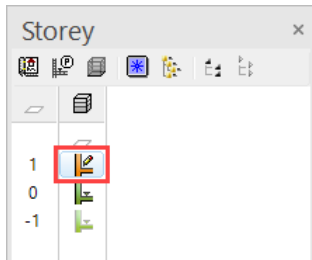

2. Switch to the view in starting position [Ctrl]+[spacebar].

3. Select the window to be copied (**P1**) (if the selection list appears, switch to the window).

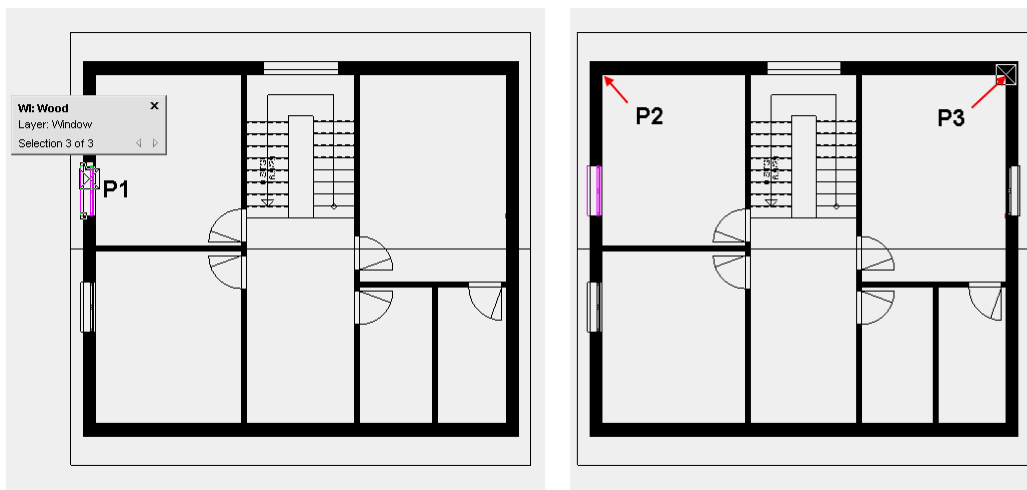

4. Select the function COPY SELECTION.



5. Determine point **P2** as reference point. The window is now "attached" to the cursor and can be repositioned. At the same time, the properties bar with additional options is shown. Mirror the window vertically.



6. Position the window in the new corner **P3** and then cancel the function with [Esc].

WORKSHOP END

ROOM LABEL

DEFINE ROOM: function

The function DEFINE ROOM sets the room label and the floor finish (3D) into the plan. In addition, various measurements of the room are calculated. These dimensions appear in the evaluation but can also be made visible in the room label.

Some values:

The room size is equal to the area within all of the adjacent walls.

The window area is the total of all windows that are entirely within the room.

Function ROOM SEPARATOR:

Often rooms are defined not just within surrounding walls but are also separated by an imaginary line, e.g. living rooms and dining rooms.

The ROOM SEPARATOR function can be used to draw a line that divides a room. The room dividing line must NOT be used to draw the entire outline of the room, but only where there are no walls. **One room-separating line on a wall leads to errors.**

▼ ▼ ▼ ▼ WORKSHOP

You will now label the rooms on the ground floor.

1. Switch the ground floor to < > *visible alone*. (double-click)

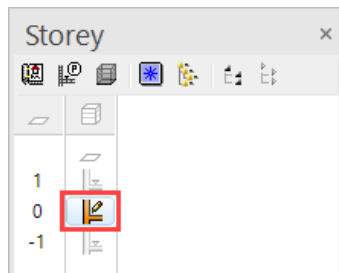

2. Start the function ROOM SEPARATOR and select the option *Draw contour*. (living room and dining room are labelled separately, the staircase is not counted as part of the forecourt)

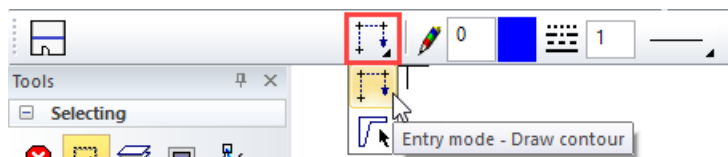

3. Draw the room separator from point **P1** to point **P2**. To complete the room separation, you need to click again on the end point **P2**.
4. Create a second room separation between the points **P3** and **P4**. To end, click again on the end point.

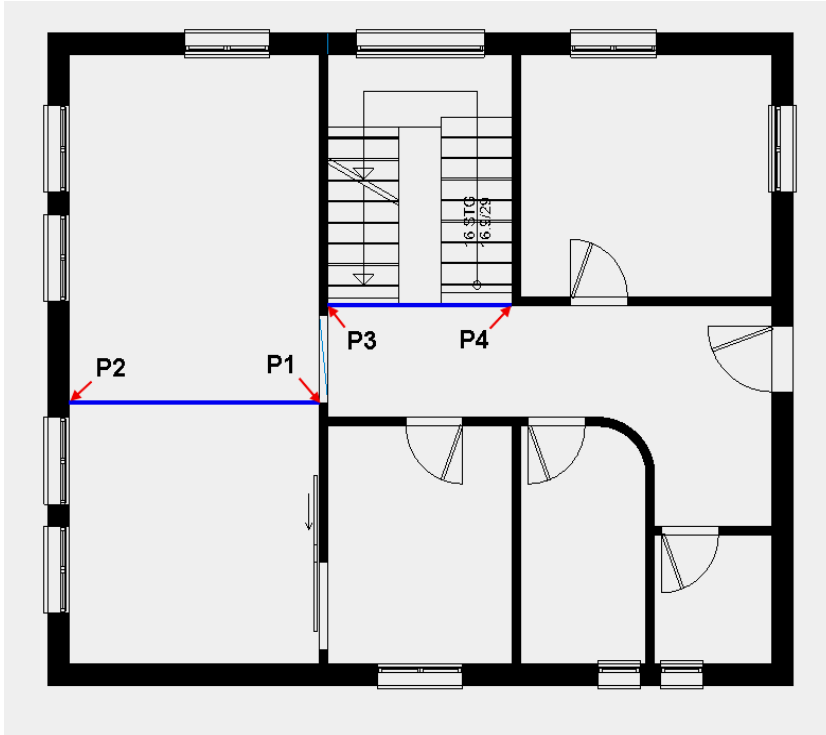

5. Cancel the function with [**Esc**].
6. Create an auxiliary drawing with help lines to be able to position the room labels.



7. Start the function ROOM and open the room parameters mask.



Select the type *Living area*.

The most important settings on the room screen are the name of the room (1), the kind of the room (2), materials (floor, wall and ceiling), the height of the floor finish (3) and the room parameters (4).

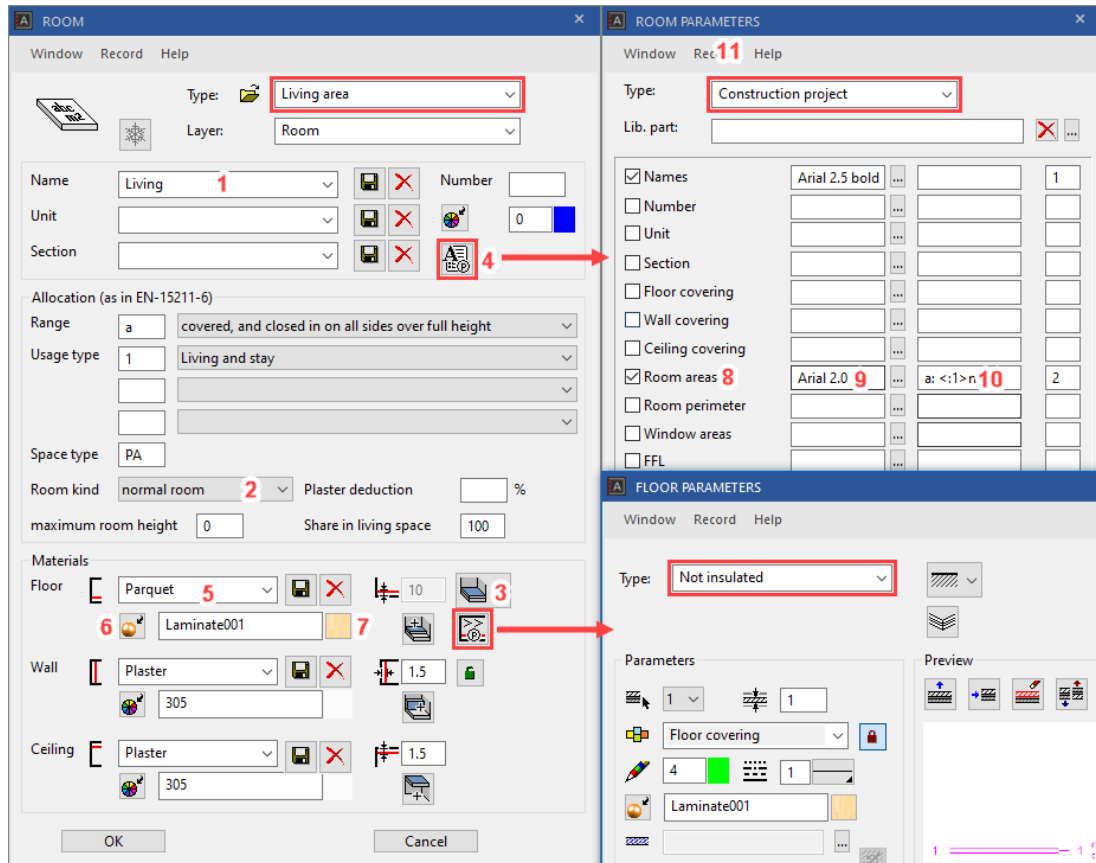

The space type and kind of room (2) are especially important for the evaluation.

A missing material name (5) can be supplemented and stored with the diskette symbol. The 3D colour and texture belonging to the material must be selected accordingly. Using the toggle key (6) the 3D colour and the texture can be selected. Both are always assigned. If you do not want any texture, please delete the entire texture name so that the texture field is blank.

Use the preview field (7) to select a texture or 3D colour.

In the room parameters mask (4) you determine which values should be displayed in the plan. Activate the desired line (8), select a text parameter (9) and the additional formatting (10) with pre-text and rounding. These room label blocks can be stored as data record (11).

In the floor parameters you can set the layer definition in detail.

8. Position the rooms **Living**, **Guest**, **Dining**, **Kitchen** and **Cupboard** with parquet flooring that has the texture */Timber/Parquet/Laminate/Laminate001* and the area type *normal room*, and the room parameter type *Floor finish*.



9. For the room **Foyer** in the room mask, change the area category from primary area (PA) to circulation area (CA).

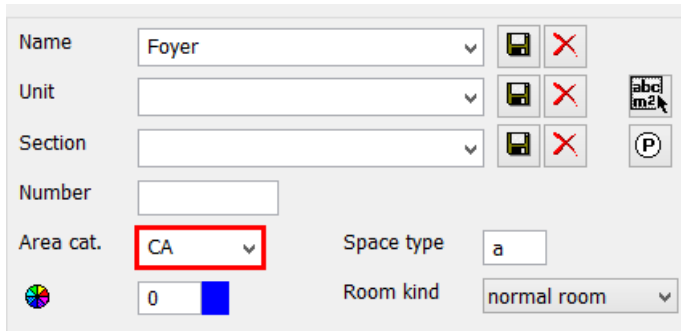

10. For the room **Bathroom** in the room mask select the type *Wet area*. The space type changes to amenity area (AA) and the floor material to **tiles**.

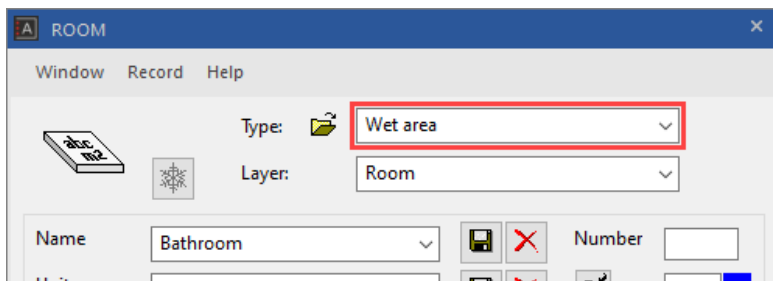

11. The last room is the staircase. To ensure that the evaluation produces a correct cubage and base area, staircases must also have a room label. Select the type *Staircase*.

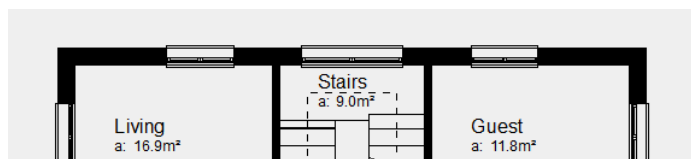
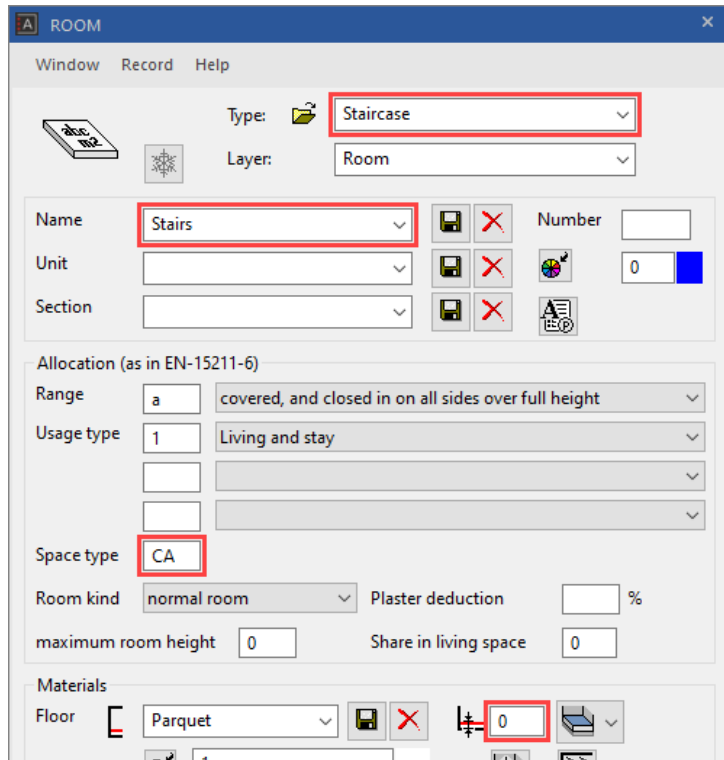

If you do not want to see any label in the outline, in the room parameters you can use the text parameter **Arial_0**, which generates a blue text that is not printed out.

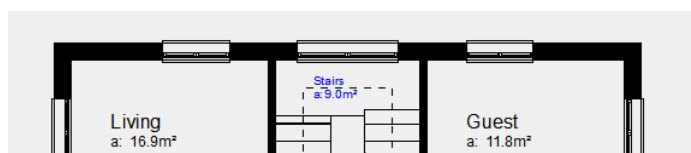
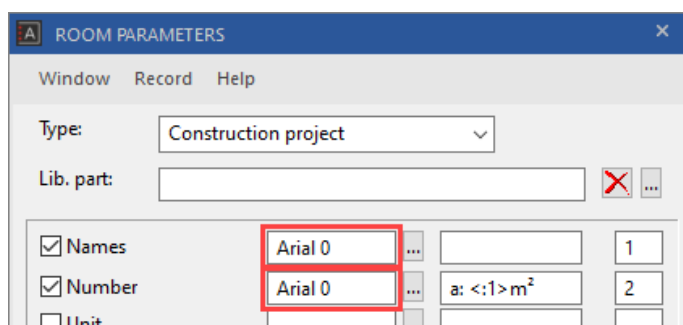

12. Delete the help lines.



SAVE

▼ ▼ ▼ ▼ WORKSHOP

The next course unit builds on the current project level. Save the model.

1. Use the function **SHOW** so that the entire model appears on the screen. If an object was selected, only this object will be displayed. If this happens, you will need to select the function again.



2. Access the save function in the menu **FILE > SAVE AS**.

The system switches to the project path *Test course*. Give the file a name; ELITECAD files end with **.d**.

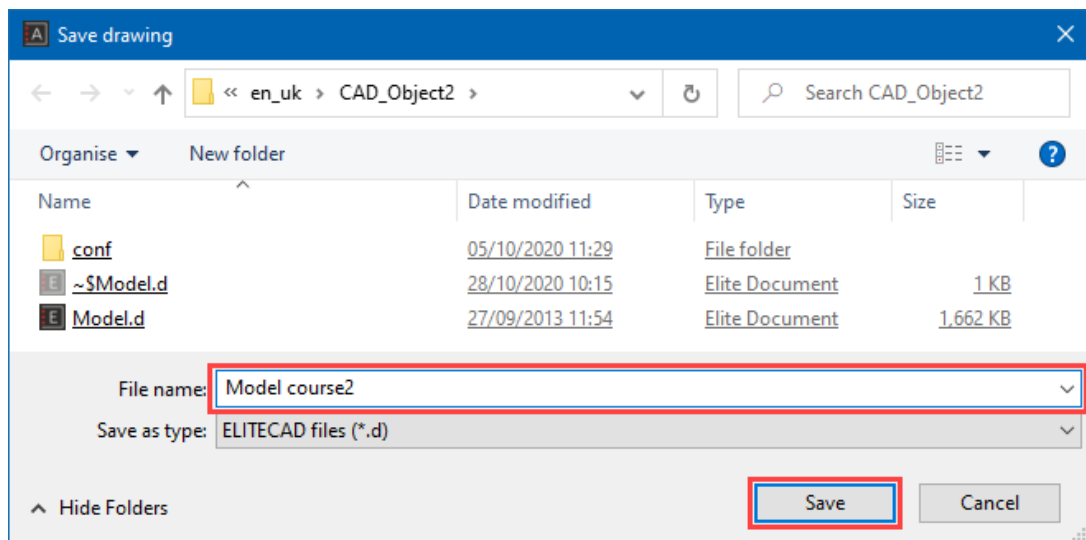

WORKSHOP END

You can now continue directly with the course unit 3.